

Display Elektronik GmbH

DATA SHEET

TFT MODULE

DEM 320480B VMH-PW-N (A-TOUCH)

3,5" TFT + Touch

Product Specification

Ver.: 1

28.05.2015

Revision History

Revision	Date	Detail	Remarks
0	16.04.2015	Initial Release	-
1	28.05.2015	Add Weight Modify Chromacity Transmissive	P4 P7

Table of Contents

No.	Item	Page
1.	General Description	4
2.	Module Parameter	4
3.	Absolute Maximum Ratings	4
4.	DC Characteristics	5
5.	Backlight Characteristic	5
5.1.	Backlight Characteristics.....	5
5.2.	Backlighting circuit	5
6.	Touch Screen Panel Specifications.....	6
7.	Optical Characteristics	7
7.1.	Optical Characteristics	7
7.2.	Definition of Response Time	7
7.3.	Definition of Contrast Ratio	8
7.4.	Definition of Viewing Angles.....	8
7.5.	Definition of Color Appearance	9
7.6.	Definition of Surface Luminance, Uniformity and Transmittance.....	9
8.	Block Diagram and Power Supply	10
9.	Interface Pins Definition	11
9.1.	FPC CON	11
10.	AC Characteristics	12
11.	Quality Assurance	17
11.1	Purpose	17
11.2	Standard for Quality Test.....	17
11.3	Nonconforming Analysis & Disposition	17
11.4	Agreement Items.....	17
11.5	Standard of the Product Visual Inspection	18
11.6	Inspection Specification	19
11.7	Classification of Defects.....	24
11.8	Identification/marketing criteria	24
11.9	Packaging	24
12.	Reliability Specification	25
13.	Precautions and Warranty	26
13.1	Safety	26
13.2	Handling	26
13.3	Storage	26
13.4	Metal Pin (Apply to Products with Metal Pins)	26
13.5	Operation	27
13.6	Static Electricity	27
13.7	Limited Warranty	27
14.	Outline Drawing	28

1. General Description

The specification is a transmissive type color active matrix liquid crystal display (LCD) which uses amorphous thin film transistor (TFT) as switching devices. This product is composed of a TFT-LCD panel, driver Ics, a touch panel and a backlight unit.

2. Module Parameter

Features	Details	Unit
Display Size (Diagonal)	3.5"	-
LCD Type	MVA TFT	-
Display Mode	Transmissive / Normally White	-
Resolution	320 x RGB x 480	Pixels
View Direction	FULL VIEW	Best Image
Module Outline	55.70 x 85.00 x 3.90 (Note1)	mm
Active Area	48.96 x 73.44	mm
Pixel Pitch	0.153 x 0.153	mm
Pixel Arrangement	RGB Vertical Stripe	-
Display Colors	262k	-
Interface	RGB or 8/9/16/18-Parallel-MCU-Interface	-
Driver IC	ILI9488 (Ilitek)	-
With or Without Touch Panel	With Touch	-
Operating Temperature	-20°C to +70°C	°C
Storage Temperature	-30°C to +80°C	°C
Weight	33	g

Note 1: Exclusive hooks, posts, FFC/FPC tail etc.

3. Absolute Maximum Ratings

GND =0V, Ta=25°C

Item	Symbol	Min.	Max.	Unit
Power Supply Voltage	V _{DD}	-0.3	3.3	V
Storage Temperature	T _{STG}	-30	+80	°C
Operating Temperature	T _{OP}	-20	+70	°C

Note 1: If Ta below 50°C, the maximal humidity is 90%RH, if Ta over 50°C, absolute humidity should be less than 60%RH.

Note 2: The response time will be extremely slow when the operating temperature is around -10°C, and the back ground will become darker at high temperature operating.

4. DC Characteristics

Item	Symbol	Min.	Typ.	Max.	Unit	
Supply Voltage	V _{DD}	2.5	2.8	3.3	V	
Logic Low Input Voltage	V _{IL}	-0.3	-	0.3*V _{DD}	V	
Logic High Input Voltage	V _{IH}	0.7*V _{DD}	-	V _{DD}	V	
Logic Low Output Voltage	V _{OL}	0	-	0.2*V _{DD}	V	
Logic High Output Voltage	V _{OH}	0.8*V _{DD}	-	V _{DD}	V	
Current Consumption All Black	Logic	I _{CC+} I _{IN}	-	10	20	mA
	Analog					

5. Backlight Characteristic

5.1. Backlight Characteristics

Item	Symbol	Condition	Min.	Typ.	Max.	Unit
Forward Voltage	V _F	Ta=25°C, I _F =20mA/LED	2.9	3.2	3.3	V
Forward Current	I _F	Ta=25°C, V _F =3.2V/LED	-	120	-	mA
Power Dissipation	P _D	-	-	384	-	mW
Uniformity	Avg	-	80	-	-	%
LED Lifetime (25°C)	-	-	-	30,000	-	Hrs
Drive Method	Constant Current					
LED Configuration	6 White LEDs in parallel					

Note: LED life time defined as follows: The final brightness is at 50% of original brightness.

The environmental conducted under ambient air flow, at Ta=25±2°C, 60%RH±5%, I_F=20mA.

5.2. Backlighting Circuit

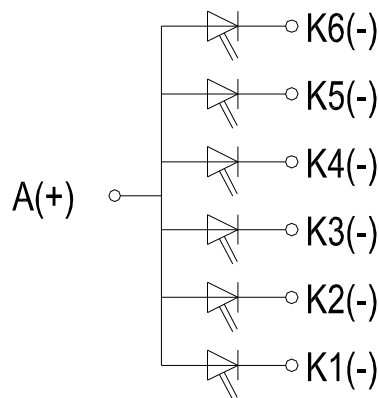

BACKLIGHT CIRCUIT

6. Touch Screen Panel Specifications**6.1 Electrical Characteristics**

Item	Min.	Typ.	Max.	Unit	Note
Linearity	-1.5	-	1.5	%	Analog X and Y directions
Terminal Resistance	100	-	500	Ω	X (Film side)
	300	-	1000	Ω	Y (Glass side)
Insulation Resistance	20	-	-	M Ω	DC \leq 10V
Voltage	-	-	10	V	DC
Chattering	-	-	10	ms	

Caution (1): Do not operate it with a thing except a polyacetal pen (tip R0.8mm or less) or a finger, especially those with hard or sharp tips such as a ball point pen or a mechanical pencil.

6.2 Mechanical & Reliability Characteristics

Item	Min.	Typ.	Max.	Unit	Note
Activation Force	20	-	100	g	(1)
Durability-Surface Scratching	Write 20,000	-	-	characters	(2)
Durability-Surface Pitting	1,000,000	-	-	touches	(3)
Surface Hardness	3	-	-	H	

Note (1) Stylus pen Input: R0.8mm polyacetal pen or Finger

Note (2) Measurement for Surface area

- Force: 150-250gf
- Speed: 60mm/sec
- Stylus: R0.8 polyacetal pen or Finger

Note (3) Pit 1,000,000 times on the Film with a R3.75 silicon rubber.

- Force: Force: 2.45N
- Speed: 3times/sec

7. Optical Characteristics

7.1. Optical Characteristics

Ta=25°C, V_{DD}=2.8V

	Item	Symbol	Condition	Specification			Unit
				Min.	Typ.	Max.	
Backlight On (Transmissive Mode)	Luminance on TFT(I _f =20mA/LED)	Lv	Normally viewing angle θ _x = φ _y = 0°	265	330	-	cd/m ²
	Contrast Ratio(See 7.3)	CR		400	500	-	
	Response Time (See 7.2)	T _R		-	16	32	ms
		T _F					
	Chromaticity Transmissive (See 7.5)	Red	X _R	0.556	0.606	0.656	-
			Y _R	0.309	0.359	0.409	-
		Green	X _G	0.251	0.301	0.351	-
			Y _G	0.559	0.609	0.659	-
		Blue	X _B	0.096	0.146	0.196	-
			Y _B	0.051	0.101	0.151	-
	White	X _W	0.242	0.292	0.342	-	
		Y _W	0.294	0.344	0.394	-	
Viewing Angle (See 7.4)	Horizontal	θ _{x+}	Center CR≥10	60	75	-	Deg.
		θ _{x-}		60	75	-	
	Vertical	φ _{y+}		60	75	-	
		φ _{y-}		60	75	-	
	NTSC Ratio(Gamut)	-	-	-	60	-	%

7.2. Definition of Response Time

7.2.1. Normally Black Type (Negative)

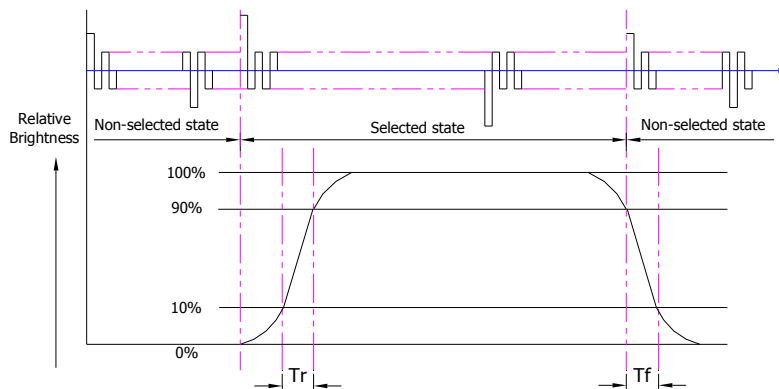

Tr is the time it takes to change from non-selected stage with relative luminance 10% to selected state with relative luminance 90%;

Tf is the time it takes to change from selected state with relative luminance 90% to non-selected state with relative luminance 10%.

Note: Measuring machine: LCD-5100

7.2.2. Normally White Type (Positive)

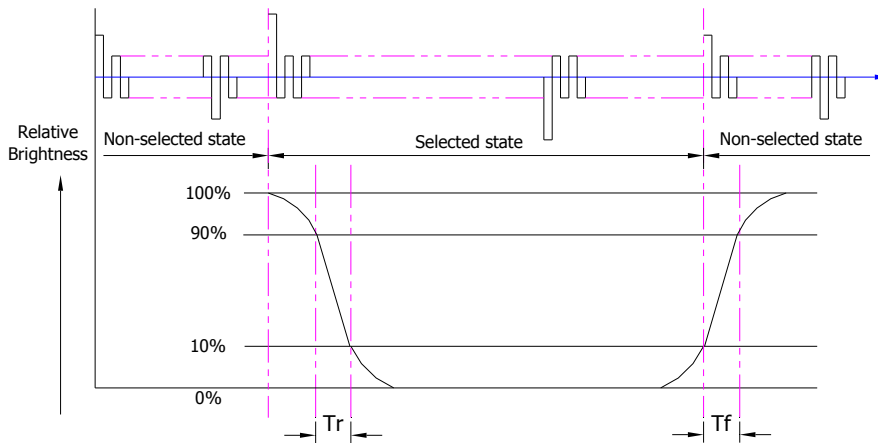

T_r is the time it takes to change from non-selected stage with relative luminance 90% to selected state with relative luminance 10%;

T_f is the time it takes to change from selected state with relative luminance 10% to non-selected state with relative luminance 90%;

Note: Measuring machine: LCD-5100 or EQUI

7.3. Definition of Contrast Ratio

Contrast is measured perpendicular to display surface in reflective and transmissive mode.

The measurement condition is:

Measuring Equipment	Eldim or Equivalent
Measuring Point Diameter	3mm//1mm
Measuring Point Location	Active Area centre point
Test pattern	A: All Pixels white
	B: All Pixel black
Contrast setting	Maximum

Definitions: CR (Contrast) = Luminance of White Pixel / Luminance of Black Pixel

7.4. Definition of Viewing Angles

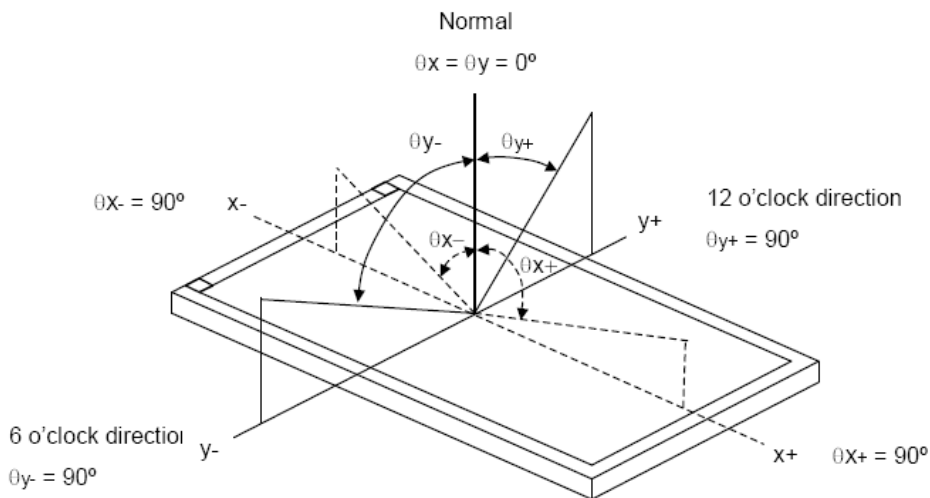

Measuring machine: LCD-5100 or EQUI

7.5. Definition of Color Appearance

R,G,B and W are defined by (x, y) on the IE chromaticity diagram

NTSC=area of RGB triangle/area of NTSC triangleX100%

Measuring picture: Red, Green, Blue and White (Measuring machine: BM-7)

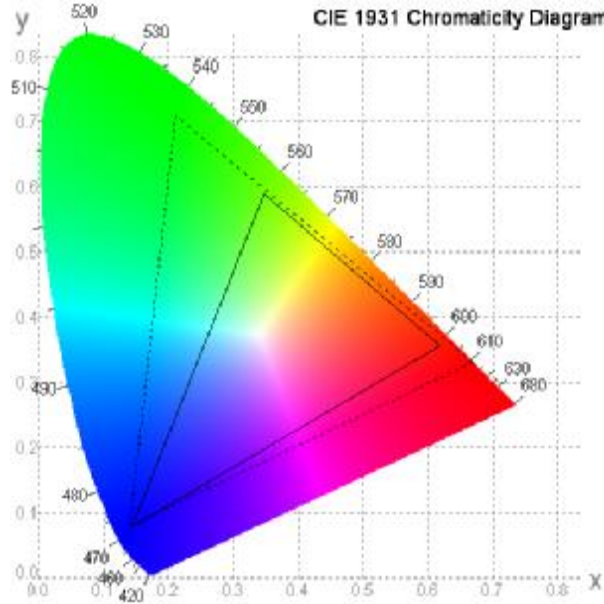

7.6. Definition of Surface Luminance, Uniformity and Transmittance

Using the transmissive mode measurement approach, measure the white screen luminance of the display panel and backlight.

- 7.6.1. Surface Luminance: $L_v = \text{average} (L_{P1}:L_{P9})$
- 7.6.2. Uniformity = $\text{Minimal} (L_{P1}:L_{P9}) / \text{Maximal} (L_{P1}:L_{P9}) * 100\%$
- 7.6.3. Transmittance = $L_v \text{ on LCD} / L_v \text{ on Backlight} * 100\%$

Note: Measuring machine: BM-7

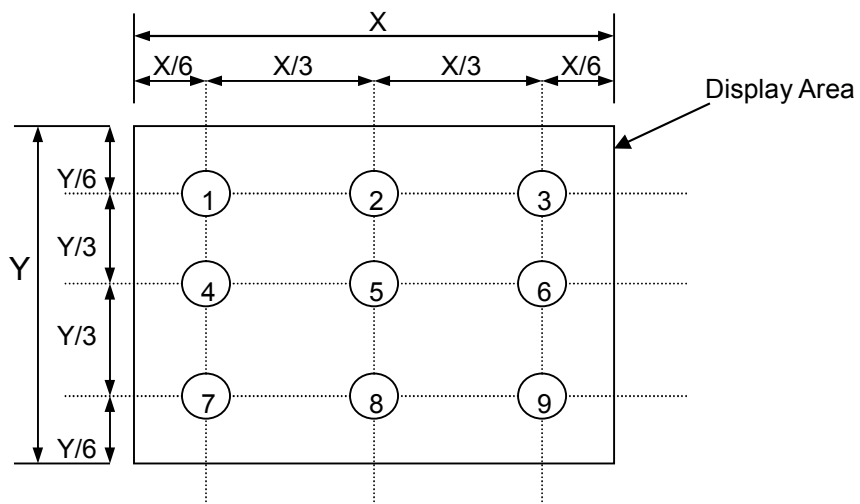

8. Block Diagram and Power Supply

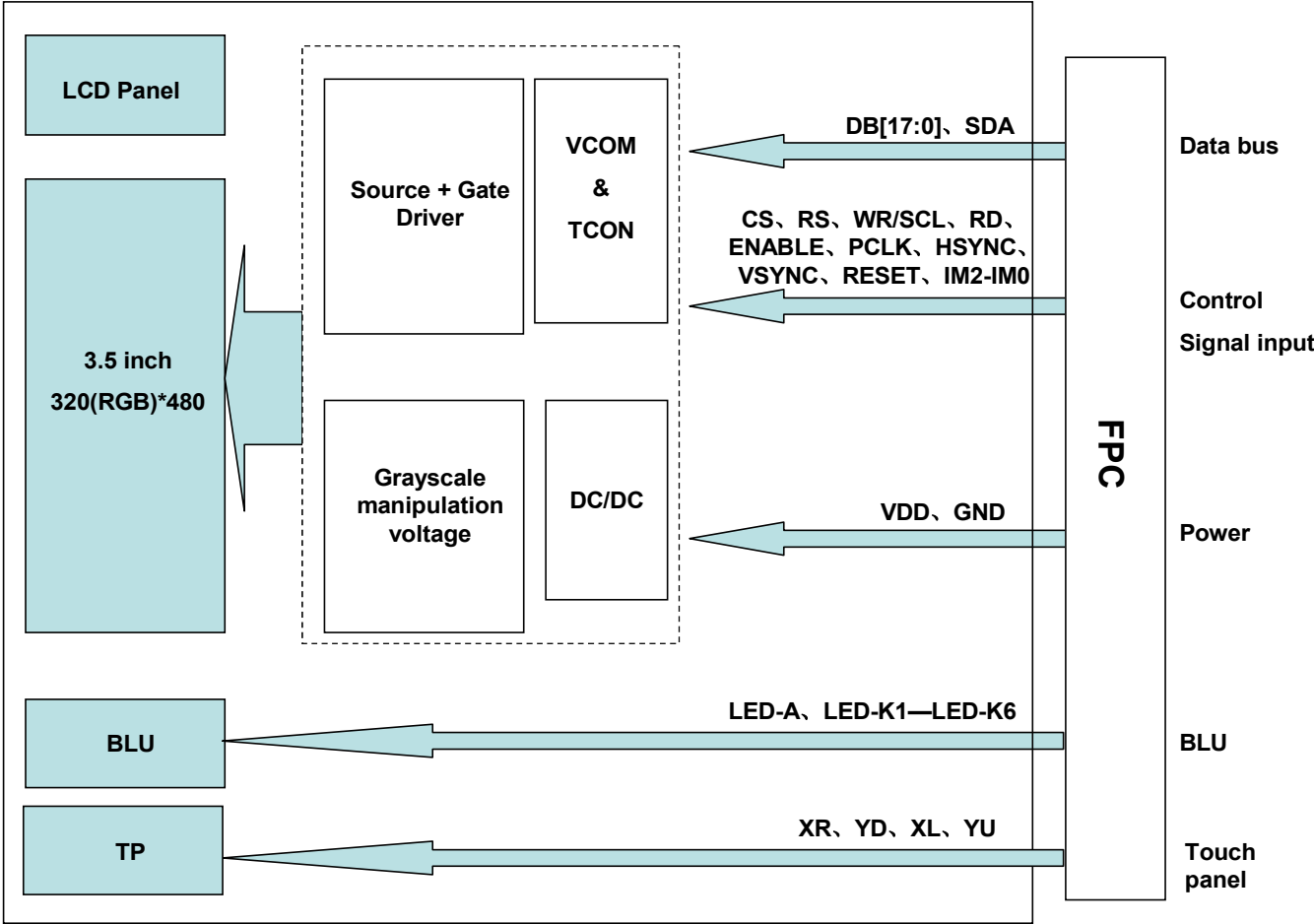

9. Interface Pins Definition

9.1. FPC CON

No.	Symbol	Function																																				
1	TE	Tearing effect output pin																																				
2	GND	Power Ground																																				
3-4	VDD	Power supply for LCM (2.8V TYPE).																																				
5	CS	Chip select signal																																				
6	RS	Command/Display data selection signal																																				
7	WR/SCL	DBI Type B:WRX pin, serves as a write signal DBI Type C:SCL pin as Serial Clock when operates in the serial interface																																				
8	RD	LCD driver read enable																																				
9	SDA	Serial data input pin.																																				
10	RESET	Reset input pin. Signal is active low.																																				
11-28	DB0-DB17	Data bus																																				
29	ENABLE	Data Enable signal.																																				
30	PCLK	Pixel clock signal for DPI I/F mode.																																				
31	HSYNC	Horizontal Sync Signal																																				
32	VSYNC	Vertical Sync Signal																																				
33 34 35	IM2 IM1 IM0	Select the MPU system interface mode:																																				
		<table border="1"> <thead> <tr> <th>IM2</th> <th>IM1</th> <th>IM0</th> <th>Interface Mode</th> </tr> </thead> <tbody> <tr> <td>0</td> <td>0</td> <td>0</td> <td>Not use</td> </tr> <tr> <td>0</td> <td>0</td> <td>0</td> <td>DBI Type B 18-bit bus(DB_EN=0)</td> </tr> <tr> <td>0</td> <td>0</td> <td>1</td> <td>DBI Type B 9-bit bus</td> </tr> <tr> <td>0</td> <td>1</td> <td>0</td> <td>DBI Type B 16-bit bus</td> </tr> <tr> <td>0</td> <td>1</td> <td>1</td> <td>DBI Type B 8-bit bus</td> </tr> <tr> <td>1</td> <td>0</td> <td>1</td> <td>DBI Type C Option 1(3-line SPI)</td> </tr> <tr> <td>1</td> <td>1</td> <td>0</td> <td>Not use</td> </tr> <tr> <td>1</td> <td>1</td> <td>1</td> <td>DBI Type C Option 1(4-line SPI)</td> </tr> </tbody> </table>	IM2	IM1	IM0	Interface Mode	0	0	0	Not use	0	0	0	DBI Type B 18-bit bus(DB_EN=0)	0	0	1	DBI Type B 9-bit bus	0	1	0	DBI Type B 16-bit bus	0	1	1	DBI Type B 8-bit bus	1	0	1	DBI Type C Option 1(3-line SPI)	1	1	0	Not use	1	1	1	DBI Type C Option 1(4-line SPI)
		IM2	IM1	IM0	Interface Mode																																	
		0	0	0	Not use																																	
		0	0	0	DBI Type B 18-bit bus(DB_EN=0)																																	
		0	0	1	DBI Type B 9-bit bus																																	
		0	1	0	DBI Type B 16-bit bus																																	
		0	1	1	DBI Type B 8-bit bus																																	
		1	0	1	DBI Type C Option 1(3-line SPI)																																	
1	1	0	Not use																																			
1	1	1	DBI Type C Option 1(4-line SPI)																																			
36	YD	Touch panel terminal																																				
37	XL	Touch panel terminal																																				
38	YU	Touch panel terminal																																				
39	XR	Touch panel terminal																																				
40-45	LED-K1-LED-K6	Cathode for back light driver voltage																																				
46	LED-A	Anode for back light driver voltage																																				
47	GND	Power Ground																																				
48-51	NC	No Connection																																				

10. AC Characteristics

10.1. DBI Type B (Display Parallel 8-/9-/16-/18-/24-bit interface) Timing Characteristics

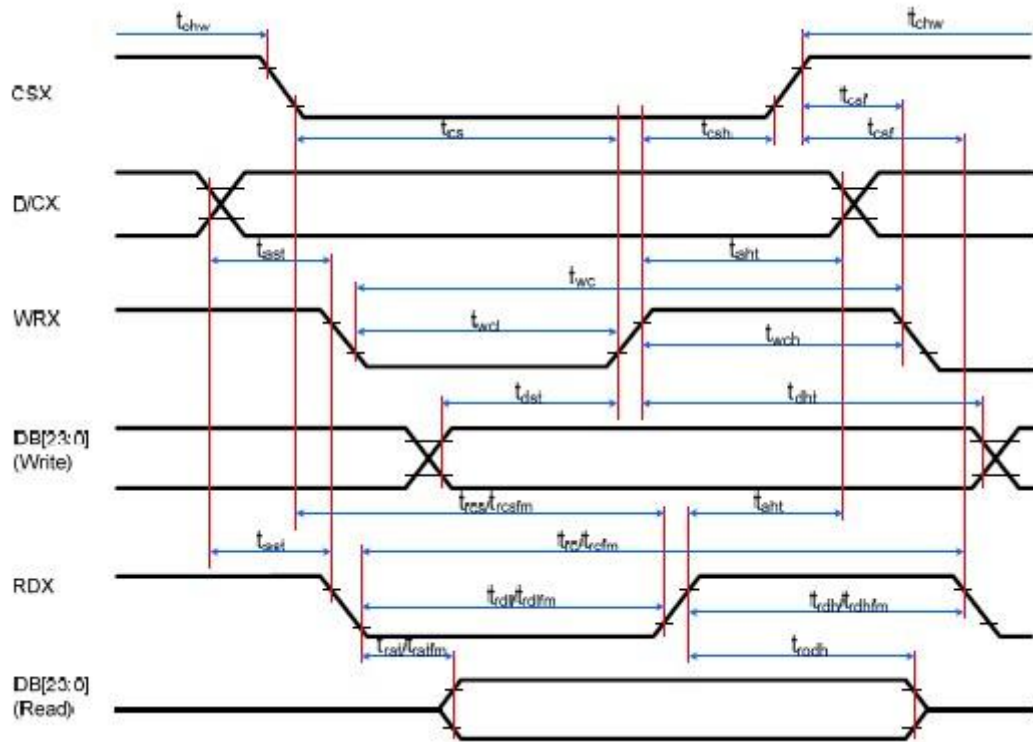

Signal	Symbol	Parameter	min	max	Unit	Description
DCX	tast	Address setup time	0	-	ns	-
	that	Address hold time (Write/Read)	0	-	ns	-
CSX	tchwh	CSX "H" pulse width	0	-	ns	-
	tcs	Chip Select setup time (Write)	15	-	ns	-
	trcs	Chip Select setup time (Read ID)	45	-	ns	-
	trcsfm	Chip Select setup time (Read FM)	355	-	ns	-
	tcsf	Chip Select Wait time (Write/Read)	0	-	ns	-
WRX	twc	Write cycle	30	-	ns	-
	twrh	Write Control pulse H duration	15	-	ns	-
	twrl	Write Control pulse L duration	15	-	ns	-
RDX (FM)	trcfm	Read Cycle (FM)	450	-	ns	When read from Frame Memory
	trclhfm	Read Control H duration (FM)	90	-	ns	
	trcllfm	Read Control L duration (FM)	355	-	ns	
RDX (ID)	trc	Read cycle (ID)	160	-	ns	When read ID data
	trdh	Read Control pulse H duration	90	-	ns	
	trdl	Read Control pulse L duration	45	-	ns	
DB [23:0], DB [17:0], DB [15:0], DB [8:0], DB [7:0]	tdst	Write data setup time	10	-	ns	For maximum, CL=30pF For minimum, CL=8pF
	tdht	Write data hold time	10	-	ns	
	trat	Read access time	-	40	ns	
	tratfm	Read access time	-	340	ns	
	trod	Read output disable time	20	80	ns	

Notes:

- 1. Ta = -30 to 70 °C, IOVCC = 1.65V to 3.3V, VCI = 2.5V to 3.3V, AGND = DGND = 0V
- 2. Logic high and low levels are specified as 30% and 70% of IOVCC for input signals.
- 3. Input signal rising time and falling time:

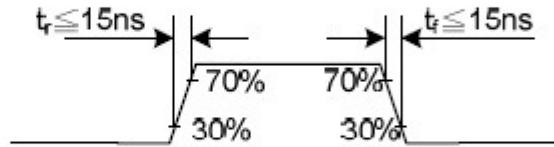

4. The CSX timing:

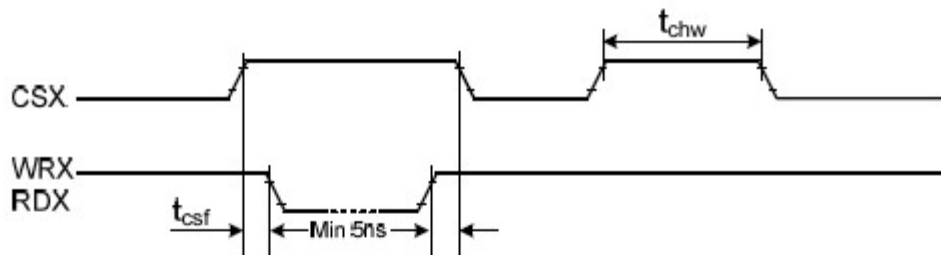

5. The Write to Read or the Read to Write timing:

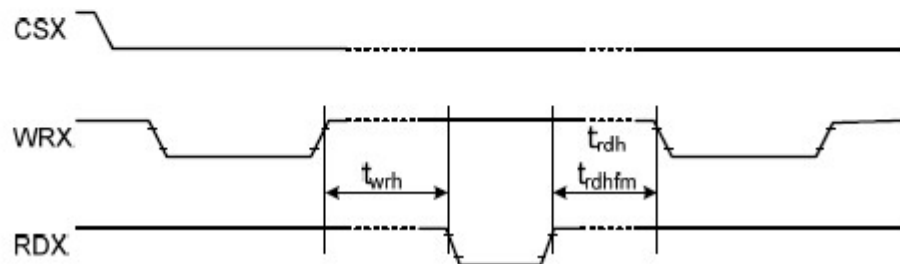

10.2. DBI Type C Option 1 (3-Line SPI System) Timing Characteristics

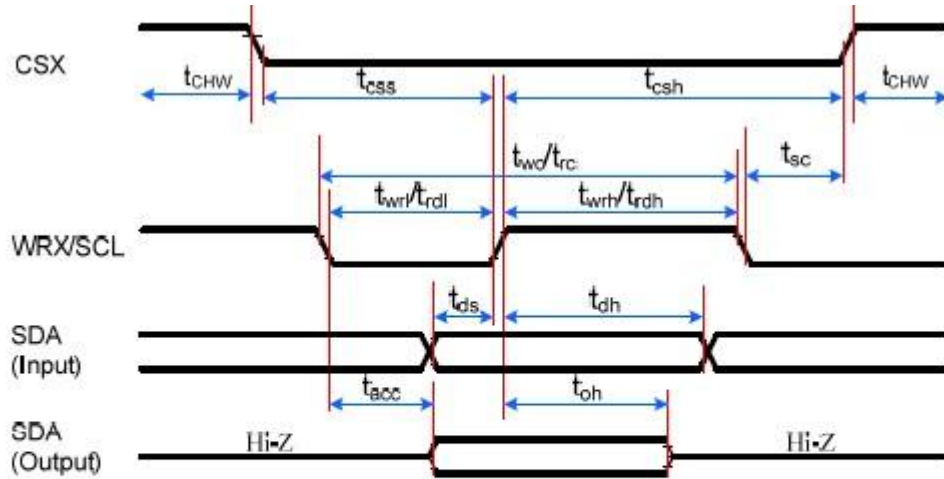

Signal	Symbol	Parameter	min	max	Unit	Description
CSX	t_{sc}	SCL-CSX	15	-	ns	
	t_{chwh}	CSX H Pulse Width	40	-	ns	
	t_{css}	Chip select time (Write)	60	-	ns	
	t_{csh}	Chip select hold time (Read)	65	-	ns	
SCL	t_{wc}	Serial Clock Cycle (Write)	66	-	ns	
	t_{wrh}	SCL H Pulse Width (Write)	15	-	ns	
	t_{wrl}	SCL L Pulse Width (Write)	15	-	ns	
	t_{rc}	Serial Clock Cycle (Read)	150	-	ns	
	t_{rdh}	SCL H Pulse Width (Read)	60	-	ns	
	t_{rdl}	SCL L Pulse Width (Read)	60	-	ns	
SDA/SDI (Input)	t_{ds}	Data setup time (Write)	10	-	ns	
	t_{dh}	Data hold time (Write)	10	-	ns	
SDA/SDO (Output)	t_{acc}	Access time (Read)	10	50	ns	For maximum CL=30pF
	t_{oh}	Output disable time (Read)	15	50	ns	For minimum CL=8pF

Note: $T_a = -30$ to 70 °C, $I_{OVCC} = 1.65V$ to $3.6V$, $V_{CI} = 2.5V$ to $3.6V$, $AGND = DGND = 0V$, $T = 10 \pm 0.5ns$

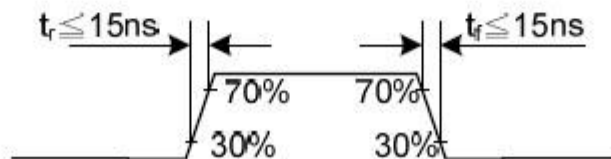

10.3. DBI Type C Option 3 (4-Line SPI System) Timing Characteristics

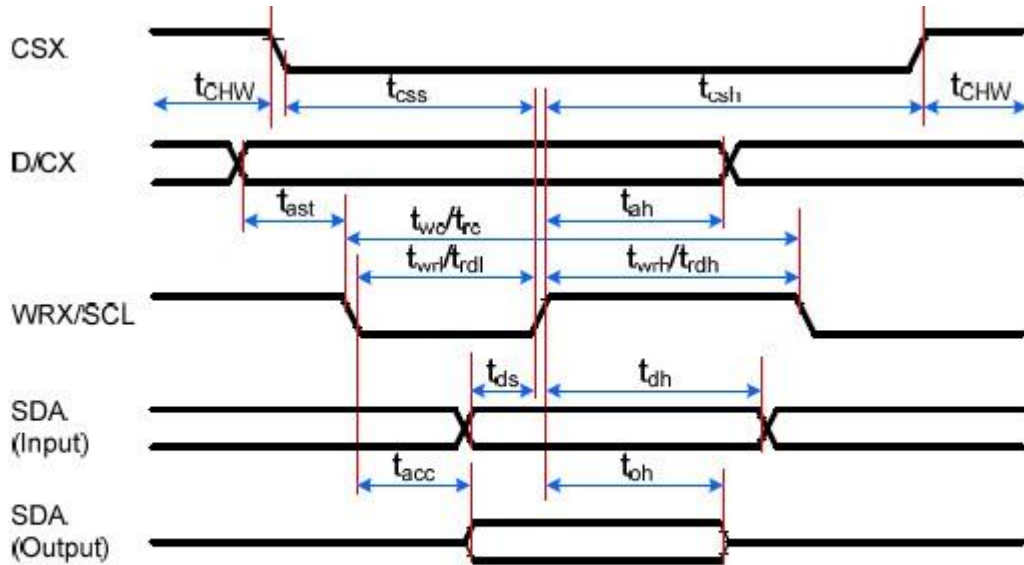

Signal	Symbol	Parameter	min	max	Unit	Description
CSX	tcss	Chip select time (Write)	15	-	ns	
	tcsh	Chip select hold time (Read)	15	-	ns	
	tCHW	CS H pulse width	40	-	ns	
SCL	twc	Serial clock cycle (Write)	50	-	ns	
	twrh	SCL H pulse width (Write)	10	-	ns	
	twrl	SCL L pulse width (Write)	10	-	ns	
	trc	Serial clock cycle (Read)	150	-	ns	
	trdh	SCL H pulse width (Read)	60	-	ns	
	trdl	SCL L pulse width (Read)	60	-	ns	
D/CX	tas	D/CX setup time	10	-	ns	
	tah	D/CX hold time (Write/Read)	10	-	ns	
SDA/SDI (Input)	tds	Data setup time (Write)	10	-	ns	
	tdh	Data hold time (Write)	10	-	ns	
SDA/SDO (Output)	tacc	Access time (Read)	10	50	ns	For maximum CL=30pF
	tod	Output disable time (Read)	15	50	ns	For minimum CL=8pF

Notes:

1. Ta = -30 to 70 °C, IOVCC = 1.65V to 3.3V, VCI = 2.5V to 3.3V, AGND = DGND = 0V, T = 10+/-0.5ns.
2. Does not include signal rising and falling times.

10.4. DPI (Display Parallel 16-/18-/24-Bit Interface) Timing Characteristics

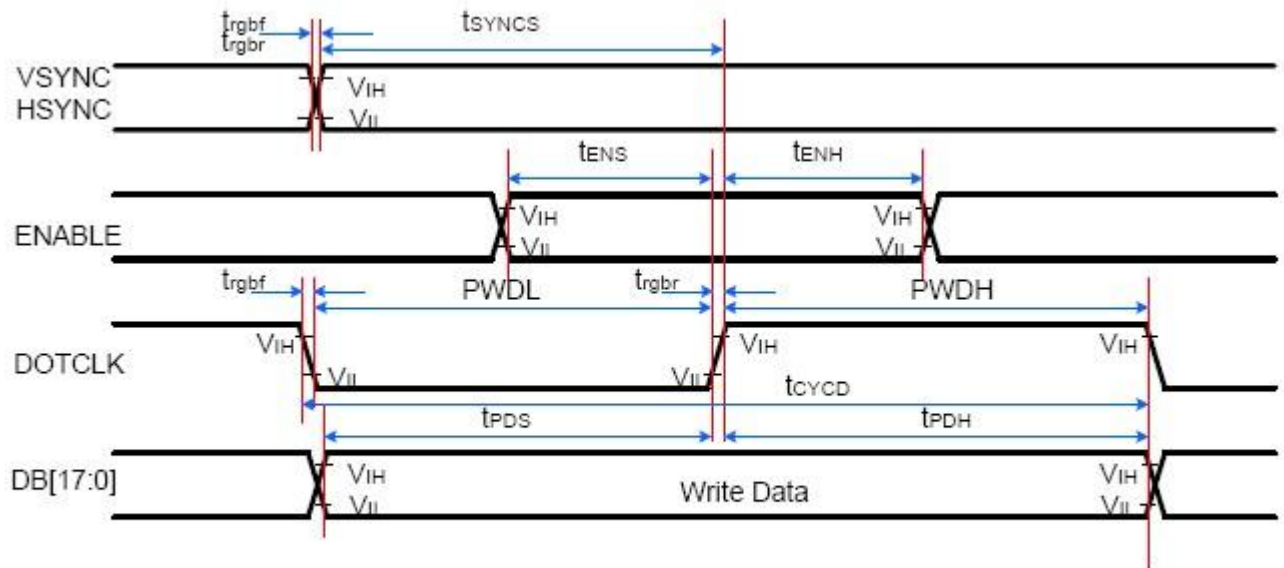

Signal	Symbol	Parameter	min	max	Unit	Description
VSYNC/ HSYNC	t_{SYNCS}	VSYNC/HSYNC setup time	15	-	ns	16-/18-/24-bit bus RGB interface mode
	t_{SYNCH}	VSYNC/HSYNC hold time	15	-	ns	
ENABLE	t_{ENS}	ENABLE setup time	15	-	ns	
	t_{ENH}	ENABLE hold time	15	-	ns	
DB [23:0]	t_{PDS}	Data setup time	15	-	ns	
	t_{PDH}	Data hold time	15	-	ns	
DOTCLK	PWDH	DOTCLK high-level period	20	-	ns	
	PWDL	DOTCLK low-level period	20	-	ns	
	t_{CYCD}	DOTCLK cycle time	50	-	ns	
	$t_{\text{rgbr}}, t_{\text{rgbf}}$	DOTCLK,HSYNC,VSYNC rise/fall time	-	15	ns	

Note: Ta = -30 to 70 °C, IOVCC = 1.65V to 3.3V, VCI = 2.5V to 3.3V, AGND = DGND = 0V

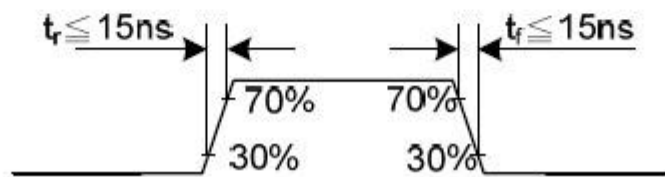

11. Quality Assurance

11.1 Purpose

This standard for Quality Assurance assures the quality of LCD module products supplied to customer.

11.2 Standard for Quality Test

11.2.1 Sampling Plan:

GB2828.1-2012

Single sampling, general inspection level II.

11.2.2 Sampling Criteria:

Visual inspection: AQL 1.5%

Electrical functional: AQL 0.65%.

11.2.3 Reliability Test:

Detailed requirement refer to Reliability Test Specification.

11.3 Nonconforming Analysis & Disposition

11.3.1 Nonconforming analysis:

11.3.1.1 Customer should provide overall information of non-conforming sample for their complaints.

11.3.1.2 After receipt of detailed information from customer, the analysis of nonconforming parts usually should be finished in one week.

11.3.1.3 If can not finish the analysis on time, customer will be notified with the progress status.

11.3.2 Disposition of nonconforming:

11.3.2.1 Non-conforming product over PPM level will be replaced.

11.3.2.2 The cause of non-conformance will be analyzed. Corrective action will be discussed and implemented.

11.4 Agreement Items

Shall negotiate with customer if the following situation occurs:

11.4.1 There is any discrepancy in standard of quality assurance.

11.4.2 Additional requirement to be added in product specification.

11.4.3 Any other special problem.

11.5 Standard of the Product Visual Inspection

11.5.1 Appearance inspection:

11.5.1.1 The inspection must be under illumination about 1000 – 1500 lx, and the distance of view must be at 30cm ± 2cm.

11.5.1.2 The viewing angle should be 45° from the vertical line without reflection light or follows customer's viewing angle specifications.

11.5.1.3 Definition of area: A Zone: Active Area, B Zone: Viewing Area,

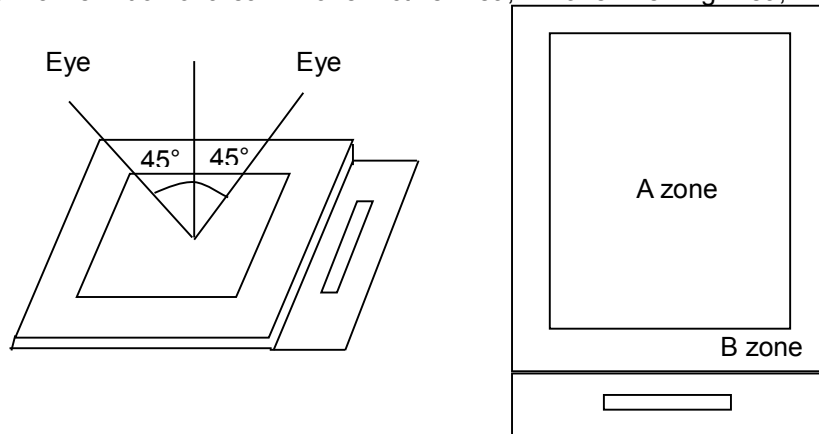

11.5.2 Basic principle:

11.5.2.1 A set of sample to indicate the limit of acceptable quality level must be discussed by both us and customer when there is any dispute happened.

11.5.2.2 New item must be added on time when it is necessary.

11.6 Inspection Specification

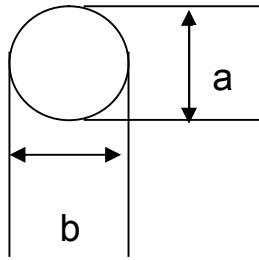
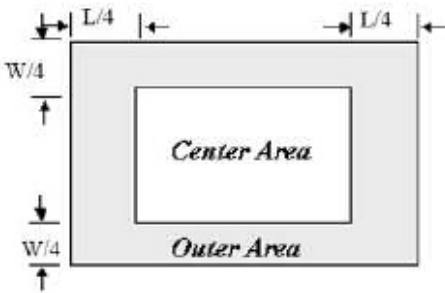
No.	Item	Criteria (Unit: mm)																		
01	Black / White spot Foreign material (Round type) Pinholes Stain Particles inside cell. (Minor defect)	 <p>$\phi = (a + b) / 2$</p> <table border="1"> <thead> <tr> <th>Size \ Area</th> <th>Acc. Qty</th> </tr> </thead> <tbody> <tr> <td>$\phi \leq 0.10$</td> <td>Ignore</td> </tr> <tr> <td>$0.10 < \phi \leq 0.15$</td> <td>2</td> </tr> <tr> <td>$0.15 < \phi \leq 0.25$</td> <td>1</td> </tr> <tr> <td>$0.25 < \phi$</td> <td>0</td> </tr> <tr> <td>Total</td> <td>2 no include $\phi \leq 0.10$</td> </tr> </tbody> </table> <p>Distance between 2 defects should more than 3mm apart.</p>	Size \ Area	Acc. Qty	$\phi \leq 0.10$	Ignore	$0.10 < \phi \leq 0.15$	2	$0.15 < \phi \leq 0.25$	1	$0.25 < \phi$	0	Total	2 no include $\phi \leq 0.10$						
		Size \ Area	Acc. Qty																	
$\phi \leq 0.10$	Ignore																			
$0.10 < \phi \leq 0.15$	2																			
$0.15 < \phi \leq 0.25$	1																			
$0.25 < \phi$	0																			
Total	2 no include $\phi \leq 0.10$																			
02	Electrical Defect (Minor defect)	<table border="1"> <thead> <tr> <th></th> <th>Display Area</th> <th>Total</th> <th>Note1</th> </tr> </thead> <tbody> <tr> <td>Bright dot</td> <td>0</td> <td>0</td> <td rowspan="3"></td> </tr> <tr> <td>Dark dot</td> <td>$N \leq 2$</td> <td>$N \leq 2$</td> </tr> <tr> <td>Total dot</td> <td>$N \leq 2$</td> <td>$N \leq 2$</td> </tr> <tr> <td>Mura</td> <td colspan="2">Not visible through 5% ND filters.</td> <td>Note 2</td> </tr> </tbody> </table> <p>Remark: 1. Bright dot caused by scratch and foreign object accords to item 1.</p>		Display Area	Total	Note1	Bright dot	0	0		Dark dot	$N \leq 2$	$N \leq 2$	Total dot	$N \leq 2$	$N \leq 2$	Mura	Not visible through 5% ND filters.		Note 2
	Display Area	Total	Note1																	
Bright dot	0	0																		
Dark dot	$N \leq 2$	$N \leq 2$																		
Total dot	$N \leq 2$	$N \leq 2$																		
Mura	Not visible through 5% ND filters.		Note 2																	
03	Inactive Area (Minor defect)	<p>Line Criteria: $L \leq 1\text{mm}$, $W \leq 0.1\text{mm}$, Dot Criteria: Please refer to Note 1,2&3</p> <p>Note1: Definition of Area</p>  <p>Note 2:</p> <table border="1"> <thead> <tr> <th>Size</th> <th>Inactive dot</th> <th>Center</th> <th>Outer</th> <th>Total</th> <th>Remark</th> </tr> </thead> <tbody> <tr> <td>All</td> <td>$\phi < 0.2\text{mm}$</td> <td colspan="4">Is not counted</td> </tr> <tr> <td><6"</td> <td>$0.2 \leq \phi \leq 0.3\text{mm}$ $L \leq 1\text{mm}, W \leq 0.1\text{mm}$</td> <td>$N \leq 1$</td> <td>$N \leq 2$</td> <td>$N \leq 3$</td> <td></td> </tr> </tbody> </table> <p>Note3: Inactive area $D < 0.2\text{mm}$ is not counted without appearance observation.</p> <p>Remark: Effective area is from the POL cutting side to 0.5mm of inside. This is no count area. Other part is effective area. In no count area, any defect can ignore. In effective area, have to judge from above-mentioned specification.</p>	Size	Inactive dot	Center	Outer	Total	Remark	All	$\phi < 0.2\text{mm}$	Is not counted				<6"	$0.2 \leq \phi \leq 0.3\text{mm}$ $L \leq 1\text{mm}, W \leq 0.1\text{mm}$	$N \leq 1$	$N \leq 2$	$N \leq 3$	
Size	Inactive dot	Center	Outer	Total	Remark															
All	$\phi < 0.2\text{mm}$	Is not counted																		
<6"	$0.2 \leq \phi \leq 0.3\text{mm}$ $L \leq 1\text{mm}, W \leq 0.1\text{mm}$	$N \leq 1$	$N \leq 2$	$N \leq 3$																

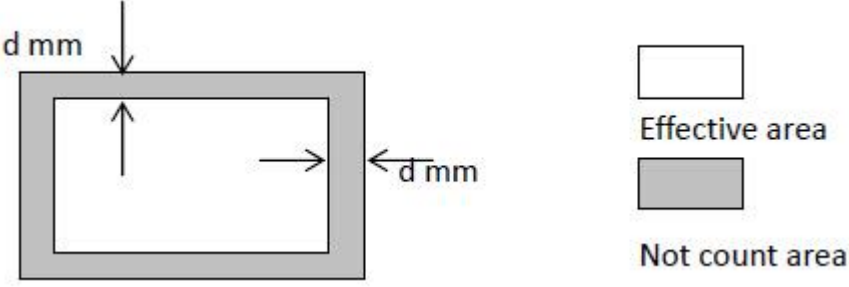
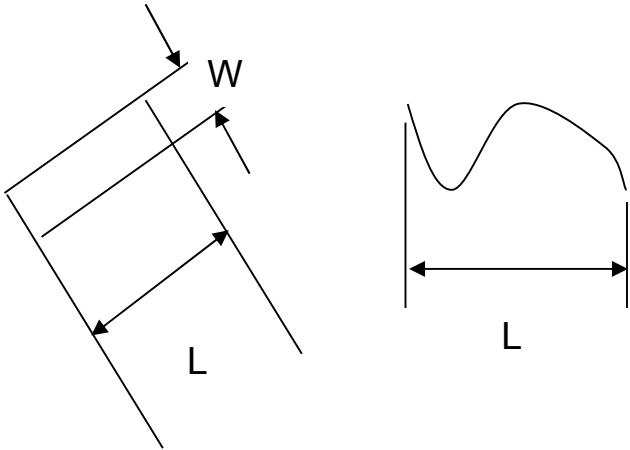
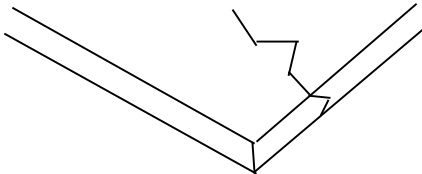
																				
<p>04</p>	<p>Black and White line Scratch Foreign material (Line type) (Minor defect)</p>	 <table border="1" data-bbox="609 1189 1235 1498"> <thead> <tr> <th>Length</th> <th>Width</th> <th>Acc. Qty</th> </tr> </thead> <tbody> <tr> <td>/</td> <td>$W \leq 0.03$</td> <td>Ignore</td> </tr> <tr> <td>$L \leq 2.5$</td> <td>$0.03 < W \leq 0.05$</td> <td>3</td> </tr> <tr> <td>$L \leq 2.5$</td> <td>$0.05 < W \leq 0.10$</td> <td>2</td> </tr> <tr> <td>/</td> <td>$0.1 < W$</td> <td>0</td> </tr> <tr> <td colspan="2">Total</td> <td>3</td> </tr> </tbody> </table> <p>Distance between 2 defects should more than 3mm apart. Scratches not viewable through the back of the display are acceptable.</p>	Length	Width	Acc. Qty	/	$W \leq 0.03$	Ignore	$L \leq 2.5$	$0.03 < W \leq 0.05$	3	$L \leq 2.5$	$0.05 < W \leq 0.10$	2	/	$0.1 < W$	0	Total		3
Length	Width	Acc. Qty																		
/	$W \leq 0.03$	Ignore																		
$L \leq 2.5$	$0.03 < W \leq 0.05$	3																		
$L \leq 2.5$	$0.05 < W \leq 0.10$	2																		
/	$0.1 < W$	0																		
Total		3																		
<p>05</p>	<p>Glass Crack (Minor defect)</p>	 <p>Crack is potential to enlarge, any type is not allowed.</p>																		

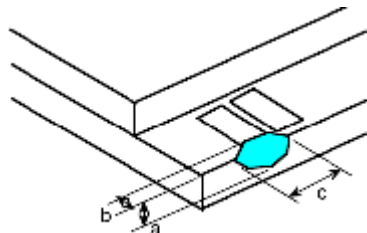
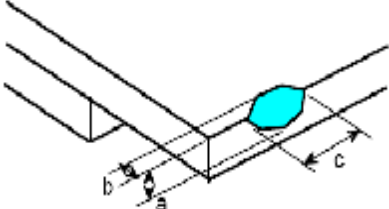
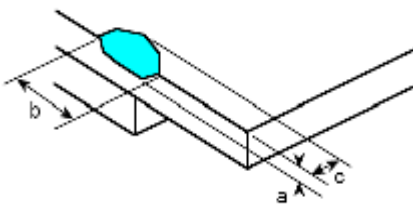
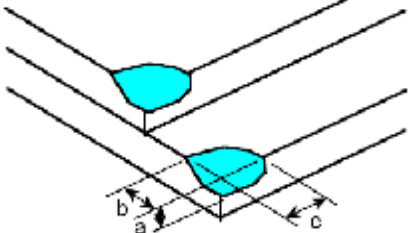
<p>06</p>	<p>Glass Chipping Pad Area: (Minor defect)</p> 	<table border="1"> <thead> <tr> <th>Length and Width</th> <th>Acc. Qty</th> </tr> </thead> <tbody> <tr> <td>$c > 3.0, b < 1.0$</td> <td>1</td> </tr> <tr> <td>$c < 3.0, b < 1.0$</td> <td>3</td> </tr> <tr> <td colspan="2" style="text-align: center;">$a < \text{Glass Thickness}$</td> </tr> </tbody> </table>	Length and Width	Acc. Qty	$c > 3.0, b < 1.0$	1	$c < 3.0, b < 1.0$	3	$a < \text{Glass Thickness}$			
Length and Width	Acc. Qty											
$c > 3.0, b < 1.0$	1											
$c < 3.0, b < 1.0$	3											
$a < \text{Glass Thickness}$												
<p>07</p>	<p>Glass Chipping Rear of Pad Area: (Minor defect)</p> 	<table border="1"> <thead> <tr> <th>Length and Width</th> <th>Acc. Qty</th> </tr> </thead> <tbody> <tr> <td>$c > 3.0, b < 1.0$</td> <td>1</td> </tr> <tr> <td>$c < 3.0, b < 1.0$</td> <td>2</td> </tr> <tr> <td>$c < 3.0, b < 0.5$</td> <td>4</td> </tr> <tr> <td colspan="2" style="text-align: center;">$a < \text{Glass Thickness}$</td> </tr> </tbody> </table>	Length and Width	Acc. Qty	$c > 3.0, b < 1.0$	1	$c < 3.0, b < 1.0$	2	$c < 3.0, b < 0.5$	4	$a < \text{Glass Thickness}$	
Length and Width	Acc. Qty											
$c > 3.0, b < 1.0$	1											
$c < 3.0, b < 1.0$	2											
$c < 3.0, b < 0.5$	4											
$a < \text{Glass Thickness}$												
<p>08</p>	<p>Glass Chipping Except Pad Area: (Minor defect)</p> 	<table border="1"> <thead> <tr> <th>Length and Width</th> <th>Acc. Qty</th> </tr> </thead> <tbody> <tr> <td>$c > 3.0, b < 1.0$</td> <td>1</td> </tr> <tr> <td>$c < 3.0, b < 1.0$</td> <td>2</td> </tr> <tr> <td>$c < 3.0, b < 0.5$</td> <td>4</td> </tr> <tr> <td colspan="2" style="text-align: center;">$a < \text{Glass Thickness}$</td> </tr> </tbody> </table>	Length and Width	Acc. Qty	$c > 3.0, b < 1.0$	1	$c < 3.0, b < 1.0$	2	$c < 3.0, b < 0.5$	4	$a < \text{Glass Thickness}$	
Length and Width	Acc. Qty											
$c > 3.0, b < 1.0$	1											
$c < 3.0, b < 1.0$	2											
$c < 3.0, b < 0.5$	4											
$a < \text{Glass Thickness}$												
<p>09</p>	<p>Glass Corner Chipping: (Minor defect)</p> 	<table border="1"> <thead> <tr> <th>Length and Width</th> <th>Acc. Qty</th> </tr> </thead> <tbody> <tr> <td>$c < 3.0, b < 3.0$</td> <td>Ignore</td> </tr> <tr> <td colspan="2" style="text-align: center;">$a < \text{Glass Thickness}$</td> </tr> </tbody> </table>	Length and Width	Acc. Qty	$c < 3.0, b < 3.0$	Ignore	$a < \text{Glass Thickness}$					
Length and Width	Acc. Qty											
$c < 3.0, b < 3.0$	Ignore											
$a < \text{Glass Thickness}$												

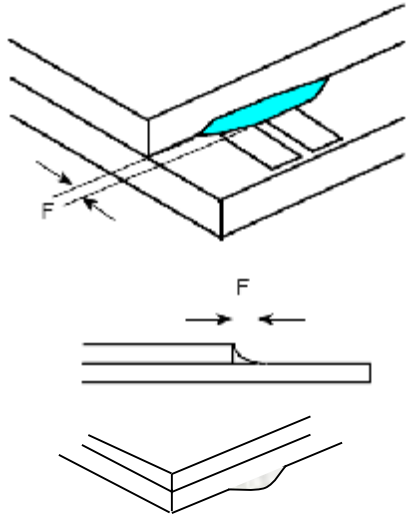
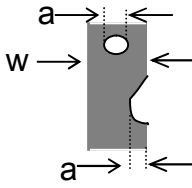
<p>10</p>	<p>Glass Burr: (Minor defect)</p> 	<table border="1" data-bbox="882 264 1355 351"> <thead> <tr> <th>Length</th> <th>Acc. Qty</th> </tr> </thead> <tbody> <tr> <td>F < 1.0</td> <td>Ignore</td> </tr> </tbody> </table> <p>Glass burr don't affect assemble and module dimension.</p>	Length	Acc. Qty	F < 1.0	Ignore						
Length	Acc. Qty											
F < 1.0	Ignore											
<p>11</p>	<p>FPC Defect: (Minor defect)</p> 	<p>11.1 Dent, pinhole width $a < w/3$. (w: circuitry width.) 11.2 Open circuit is unacceptable. 11.3 No oxidation, contamination and distortion.</p>										
<p>12</p>	<p>Bubble on Polarizer (Minor defect)</p>	<table border="1" data-bbox="758 1296 1230 1512"> <thead> <tr> <th>Diameter</th> <th>Acc. Qty</th> </tr> </thead> <tbody> <tr> <td>$\varphi \leq 0.20$</td> <td>Ignore</td> </tr> <tr> <td>$0.20 < \varphi \leq 0.30$</td> <td>4</td> </tr> <tr> <td>$0.30 < \varphi \leq 0.50$</td> <td>1</td> </tr> <tr> <td>$0.50 < \varphi$</td> <td>None</td> </tr> </tbody> </table>	Diameter	Acc. Qty	$\varphi \leq 0.20$	Ignore	$0.20 < \varphi \leq 0.30$	4	$0.30 < \varphi \leq 0.50$	1	$0.50 < \varphi$	None
Diameter	Acc. Qty											
$\varphi \leq 0.20$	Ignore											
$0.20 < \varphi \leq 0.30$	4											
$0.30 < \varphi \leq 0.50$	1											
$0.50 < \varphi$	None											
<p>13</p>	<p>Dent on Polarizer (Minor defect)</p>	<table border="1" data-bbox="758 1572 1230 1787"> <thead> <tr> <th>Diameter</th> <th>Acc. Qty</th> </tr> </thead> <tbody> <tr> <td>$\varphi \leq 0.20$</td> <td>Ignore</td> </tr> <tr> <td>$0.20 < \varphi \leq 0.30$</td> <td>4</td> </tr> <tr> <td>$0.30 < \varphi \leq 0.50$</td> <td>1</td> </tr> <tr> <td>$0.50 < \varphi$</td> <td>None</td> </tr> </tbody> </table>	Diameter	Acc. Qty	$\varphi \leq 0.20$	Ignore	$0.20 < \varphi \leq 0.30$	4	$0.30 < \varphi \leq 0.50$	1	$0.50 < \varphi$	None
Diameter	Acc. Qty											
$\varphi \leq 0.20$	Ignore											
$0.20 < \varphi \leq 0.30$	4											
$0.30 < \varphi \leq 0.50$	1											
$0.50 < \varphi$	None											
<p>14</p>	<p>Bezel</p>	<p>14.1 No rust, distortion on the Bezel. 14.2 No visible fingerprints, stains or other contamination.</p>										

<p>15</p>	<p>Touch Panel</p>	<p>D: Diameter W: width L: length 15.1 Spot: $D < 0.25$ is acceptable $0.25 \leq D \leq 0.4$ 2dots are acceptable and the distance between defects should more than 10 mm. $D > 0.4$ is unacceptable 15.2 Dent: $D > 0.40$ is unacceptable 15.3 Scratch: $W \leq 0.03$, $L \leq 10$ is acceptable, $0.03 < W \leq 0.10$, $L \leq 10$ is acceptable Distance between 2 defects should more than 10 mm. $W > 0.10$ is unacceptable.</p>
<p>16</p>	<p>LCD Ripple</p>	<p>Touch the touch panel, cannot see the LCD ripple. Pen: R 0.8mm silicon rubber. Operation Force:100g</p>
<p>17</p>	<p>PCB</p>	<p>17.1 No distortion or contamination on PCB terminals. 17.2 All components on PCB must same as documented on the BOM/component layout. 17.3 Follow IPC-A-600F.</p>
<p>18</p>	<p>Soldering</p>	<p>Follow IPC-A-610C standard</p>
<p>19</p>	<p>Electrical Defect (Major defect)</p>	<p>The below defects must be rejected. 19.1 Missing vertical / horizontal segment, 19.2 Abnormal Display. 19.3 No function or no display. 19.4 Current exceeds product specifications. 19.5 LCD viewing angle defect. 19.6 No Backlight. 19.7 Dark Backlight. 19.8 Touch Panel no function.</p>

Remark: LCD Panel Broken shall be rejected. Defect out of LCD viewing area is acceptable.

11.7 Classification of Defects

11.7.1 Visual defects (Except no / wrong label) are treated as minor defect and electrical defect is major.

11.7.2 Two minor defects are equal to one major in lot sampling inspection.

11.8 Identification/marketing criteria

Any unit with illegible / wrong /double or no marking/ label shall be rejected.

11.9 Packaging

11.9.1 There should be no damage of the outside carton box, each packaging box should have one identical label.

11.9.2 Modules inside package box should have compliant mark.

11.9.3 All direct package materials shall offer ESD protection

Note1: Bright dot is defined as the defective area of the dot is larger than 50% of one sub-pixel area.

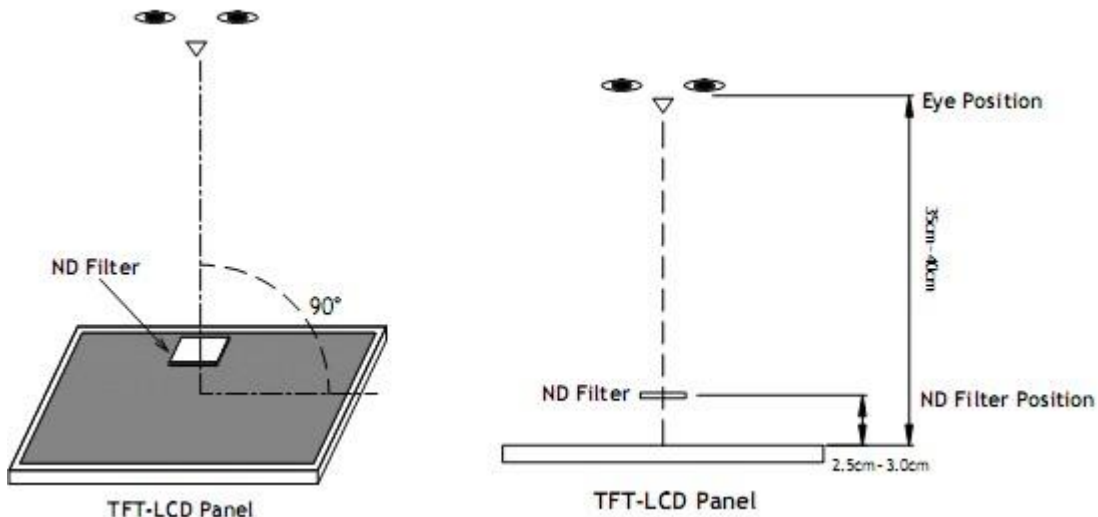

Bright dot: The bright dot size defect at black display pattern. It can be recognized by 2% transparency of filter when the distance between eyes and panel is 350mm ± 50mm.

Dark dot: Cyan, Magenta or Yellow dot size defect at white display pattern. It can be recognized by 5% transparency of filter when the distance between eyes and panel is 350mm ± 50mm.

Note2: Mura on display which appears darker / brighter against background brightness on parts of display area.

12. Reliability Specification

No	Item	Condition	Quantity	Criteria
1	High Temperature Operating	70°C, 96Hrs	2	GB/T2423.2-2008
2	Low Temperature Operating	-20°C, 96Hrs	2	GB/T2423.1-2008
3	High Humidity	50°C, 90%RH, 96Hrs	2	GB/T2423.3-2006
4	High Temperature Storage	80°C, 96Hrs	2	GB/T2423.2-2008
5	Low Temperature Storage	-30°C, 96Hrs	2	GB/T2423.1-2008
6	Thermal Cycling Test	-20°C, 60min~70°C, 60min, 20 cycles.	2	GB/T2423.22-2012
7	Packing vibration	Frequency range:10Hz~50Hz Acceleration of gravity:5G X, Y, Z 30 min for each direction.	2	GB/T5170.14-2009
8	Electrical Static Discharge	Air: ±8KV 150pF/330Ω 5 times Contact: ±4KV 150pF/330Ω 5 times	2	GB/T17626.2-2006
9	Drop Test (Packaged)	Height:80 cm,1 corner, 3 edges, 6 surfaces.	2	GB/T2423.8-1995

Note1. No defection cosmetic and operational function allowable.

Note2. Total current Consumption should be below double of initial value

13. Precautions and Warranty

13.1 Safety

13.1.1 The liquid crystal in the LCD is poisonous. Do not put it in your mouth. If the liquid crystal touches your skin or clothes, wash it off immediately using soap and water.

13.1.2 Since the liquid crystal cells are made of glass, do not apply strong impact on them. Handle with care.

13.2 Handling

13.2.1 Reverse and use within ratings in order to keep performance and prevent damage.

13.2.2 Do not wipe the polarizer with dry cloth, as it might cause scratch. If the surface of the LCD needs to be cleaned, wipe it swiftly with cotton or other soft cloth soaked with petroleum IPA, do not use other chemicals.

13.3 Storage

13.3.1 Do not store the LCD module beyond the specified temperature ranges.

13.4 Metal Pin (Apply to Products with Metal Pins)

13.4.1 Pins of LCD and Backlight

13.4.1.1 Solder tip can touch and press on the tip of Pin LEAD during the soldering

13.4.1.2 Recommended Soldering Conditions

Solder Type: Sn96.3~94-Ag3.3~4.3-Cu0.4~1.1

Maximum Solder Temperature: 370℃

Maximum Solder Time: 3s at the maximum temperature

Recommended Soldering Temp: 350±20℃

Typical Soldering Time: ≤3s

13.4.1.3 Solder Wetting

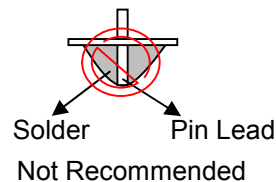
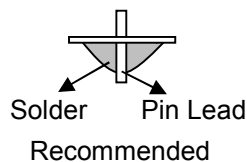

13.4.2 Pins of EL

13.4.2.1 Solder tip can touch and press on the tip of EL leads during soldering.

13.4.2.2 No Solder Paste on the soldering pad on the motherboard is recommended.

13.4.2.3 Recommended Soldering Conditions

Solder type: Nippon Alimit Leadfree SR-34, size 0.5mm

Recommended Solder Temperature: 270~290℃

Typical Soldering Time: ≤2s

Minimum solder distance from EL lamp (body):2.0mm

13.4.2.4 No horizontal press on the EL leads during soldering.

13.4.2.5 180° bend EL leads three times is not allowed.

13.4.2.6 Solder Wetting

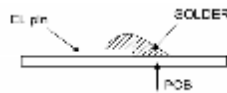

Recommended

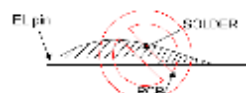

Not Recommended

13.4.2.7 The type of the solder iron:

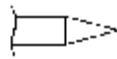

Recommended

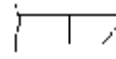

Not Recommended

13.4.2.8 Solder Pad

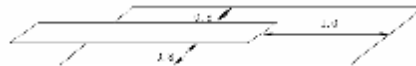

13.5 Operation

- 13.5.1 Do not drive LCD with DC voltage
- 13.5.2 Response time will increase below lower temperature
- 13.5.3 Display may change color with different temperature
- 13.5.4 Mechanical disturbance during operation, such as pressing on the display area, may cause the segments to appear “fractured”.

13.6 Static Electricity

- 13.6.1 CMOS LSIs are equipped in this unit, so care must be taken to avoid the electro-static charge, by ground human body, etc.
- 13.6.2 The normal static prevention measures should be observed for work clothes and benches.
- 13.6.3 The module should be kept into anti-static bags or other containers resistant to static for storage.

13.7 Limited Warranty

- 13.7.1 Our warranty liability is limited to repair and/or replacement. We will not be responsible for any consequential loss.
- 13.7.2 If possible, we suggest customer to use up all modules in six months. If the module storage time over twelve months, we suggest that recheck it before the module be used.
- 13.7.3 After the product shipped, any product quality issues must be feedback within three months, otherwise, we will not be responsible for the subsequent or consequential events.

14. Outline Drawing

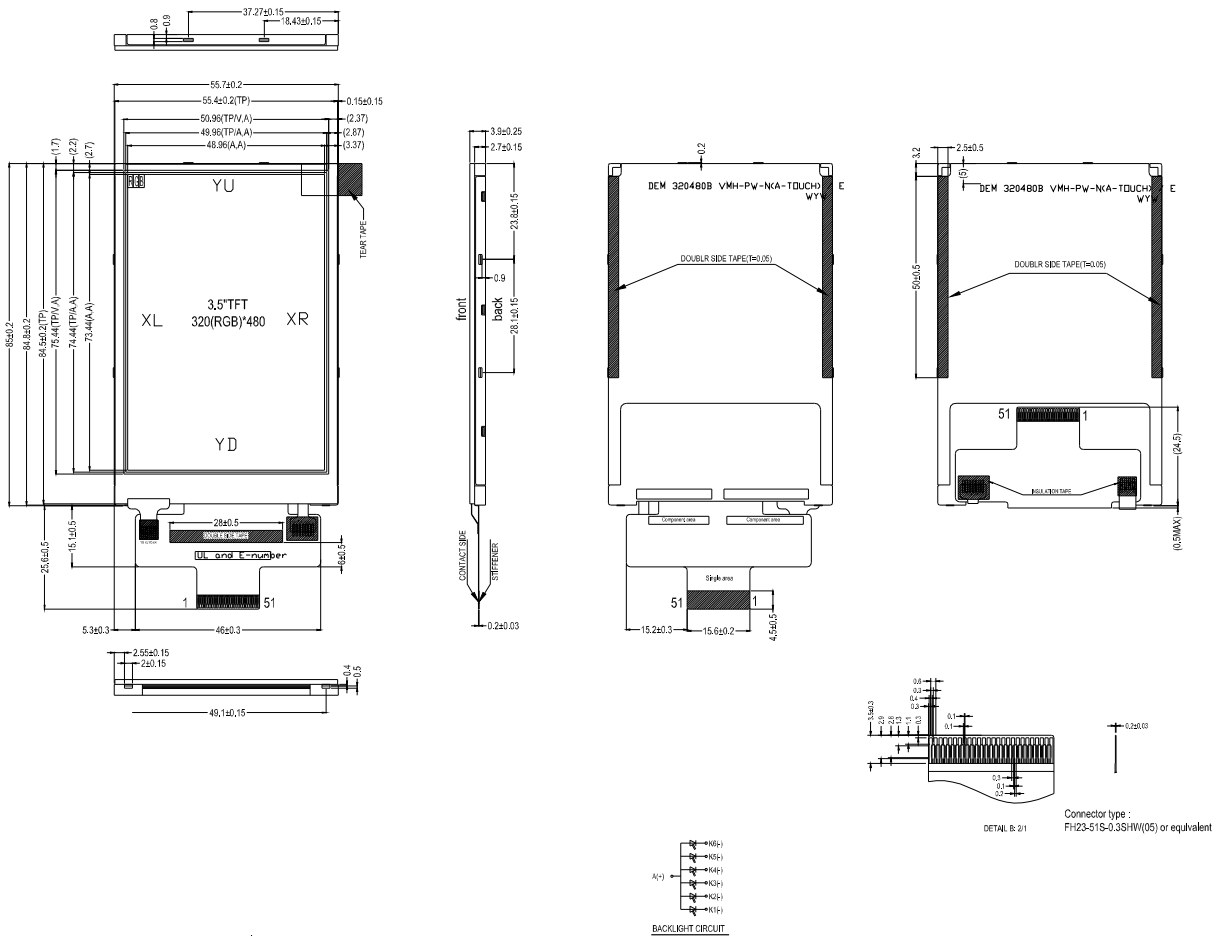

- NOTES:
1. Display Type: 3.5\"TFT
 2. Viewing Direction: Full viewing
 3. Polarizer Mode: MVA, Transmissive / Normal White
 4. Operation Temperature: -20°C to +70°C
 5. Storage Temperature: -30°C to +80°C
 6. Driver/Controller IC: Ilitek, IL9488
 7. Logic Power Supply Voltage: 2.8 Volt (typ.)
 8. Backlight: White (6xLEDs) / 3.2 Volt / 120mA (typ.)
 9. Luminance: 330cd/m2 (typ.)
 10. LED Lifetime: 30000h (typ.)
 11. ROHS must be complied
- * Unspecification tolerance are ±0.2mm

PIN	SYMBOL
1	TE
2	GND
3	VDD
4	VDD
5	CS
6	RS
7	WR/SCRL
8	RD
9	SDA
10	RESET
11	DB0
12	DB1
13	DB2
14	DB3
15	DB4
16	DB5
17	DB6
18	DB7
19	DB8
20	DB9
21	DB10
22	DB11
23	DB12
24	DB13
25	DB14
26	DB15
27	DB16
28	DB17
29	ENABLE
30	PCLK
31	HSYNC
32	VST/VS
33	BU2
34	BU1
35	BU0
36	NC(YD)
37	NC(XL)
38	NC(YU)
39	NC(XR)
40	LED-X1
41	LED-X2
42	LED-X3
43	LED-X4
44	LED-X5
45	LED-X6
46	LED-X
47	GND
48	NC
49	NC
50	NC
51	NC