

## Low voltage NV/NH knife-blade fuse-links

### NV KOMBI advantages

ETI is introducing a new generation of low-voltage fuse-links from size NV00C up to NV3 with new, dual indication of fuse-link operation, called KOMBI. The indicator is easily visible on the top and centre of the fuse-link, whether it is situated in a standard fuse base or vertical fuse rail or in fuse-switch disconnecter.

The most important advantages of NV/NH KOMBI fuse-links:

- High breaking capacity, 120 kA
- Rated voltages: 400 V a.c., 500 V a.c., 690 V a.c. and 1000 V a.c.
- Two versions of covers: aluminium, when the removal tag is under voltage and plastic, when insulated metal removal tag is incorporated into the plastic cover
- VDE certificates and CCA/CB test reports

### General about NV/NH fuse-links

Their dimensions correspond with DIN 43620, other technical characteristics correspond with the requirements of the following standards:

- Rated voltage 400V/500V/690V/gG: IEC 60269-1:2005 / EN 60269-1:1998+A1:2005 IEC 60269-2:1986+Corr.1:1996+A11995+A2:2001 / EN 60269-2:1995+A1:1998+A2:2002 IEC 60269-2-1:2004 / HD 60269-2-1:2005
- Rated voltage 690V/aM: VDE 0636-2011
- Rated voltage 400V/gF: PN-IEC 60269-2
- Rated voltage 400V/gTr: VDE 0636-2011

### Short description of constituent parts for NV fuse-links

The body of the fuse-link is made of quality steatite which is highly resistant against temperature overloads.

In the inner part of the steatite body there is a copper melting element which is welded on a specially shaped inner part of the contact knife by spot welding. By careful shaping of this part we achieved that during assembly the melting element is placed exactly into the middle of the inner place. The remaining inside place of the ceramic body is filled up with precisely determined granulation and chemical structure quartz sand. All contact knives are additionally protected with a layer of silver or on special order of nickel. On the base of cyclic tests we have proved that the fusing characteristics are very stable and the tolerance on the current axis can be up to  $\pm 10\%$ .

Electrical characteristics	
Rated voltage $U_n$	400 V AC, 500 V AC, 690 V AC
Rated current $I_n$	2 - 1600 A
Breaking capacity at $1,1 U_n$	120 kA
Fusing characteristics	gG, aM, gF, gTr
Certified according to	DIN VDE0636-201 (1998-06)
Comply with	IEC 60269-1:2005 / EN 60269-1:1998+A1:2005 IEC 60269-2:1986+Corr.1:1996+A11995+A2:2001 / EN 60269-2:1995+A1:1998+A2:2002 IEC 60269-2-1:2004 / HD 60269-2-1:2005
Dimensions comply with the standard	DIN43620 Part: 1 - 4
Two versions of covers	aluminium and plastic

Fuse-link NV/NH gG

type	dimensions											
	A	B	C	D	E	F	G	H	I	J	K	
NV00C	79	53	47	35	15	21	52	7,5			6	kombi
NV00C I	79	53	47	35	15	21	52	7,5			6	kombi
NV00	79	53	47	35	15	28	56	12			6	kombi
NV00 I	79	53	47	35	15	28	56	12			6	kombi
NV0	125	68	65	35	15	28	56	12			6	kombi
NV1C	135	68	65	40	15	28	61	12			6	kombi
NV1C I	135	68	65	40	15	28	61	12			6	kombi
NV1	135	72	65	40	20	46	65	14			6	kombi
NV1 I	135	72	65	40	20	46	65	14			6	kombi
NV2C	150	72	65	48	20	46	73	14			6	kombi
NV2C I	150	72	65	48	20	46	73	14			6	kombi
NV2	150	72	65	48	26	54	73	14			6	kombi
NV2 I	150	72	65	48	26	54	73	14			6	kombi
NV3C	150	72	65	60	26	54	84	14			6	kombi
NV3	150	72	65	60	33	65	84	14			6	kombi
NV4	200	75	66	87	50	100	121	24	150	16	8	
NV4a	200	99	87	85	50	95	121	27			6	
NV4a S1*	200	99	87	85	50	95	121	27			6	
NV1/1000V	155	90	87	40	20	45	59	9			6	

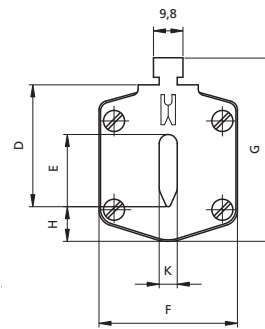
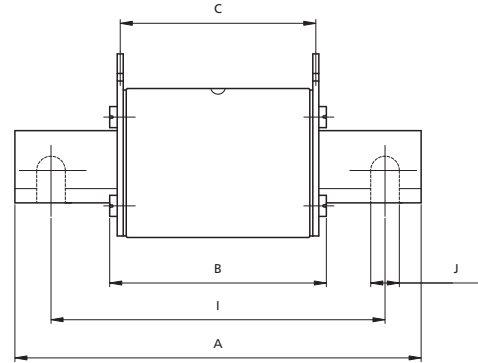

Fuse link NV/NH gG with striker pin

type	dimensions			
	K	L	M	S1
00C	0	20.7	16.7	7.5
00	0	20.7	16.7	7.5
1	13.7	19.7	25	12
2	16.2	27.4	25	12
3	17	35.6	25	12
4a	24	49	25	12

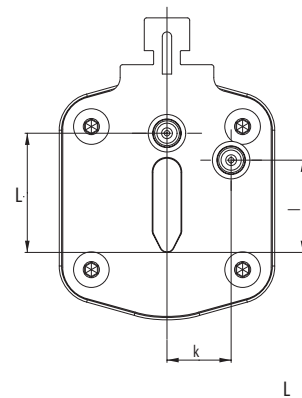
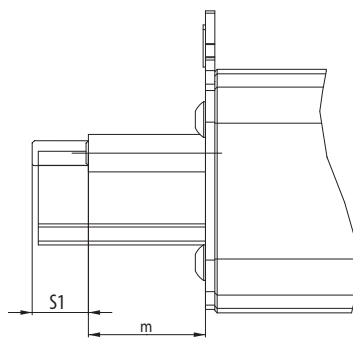

M

K

Fuse-link NV/NH gG characteristics

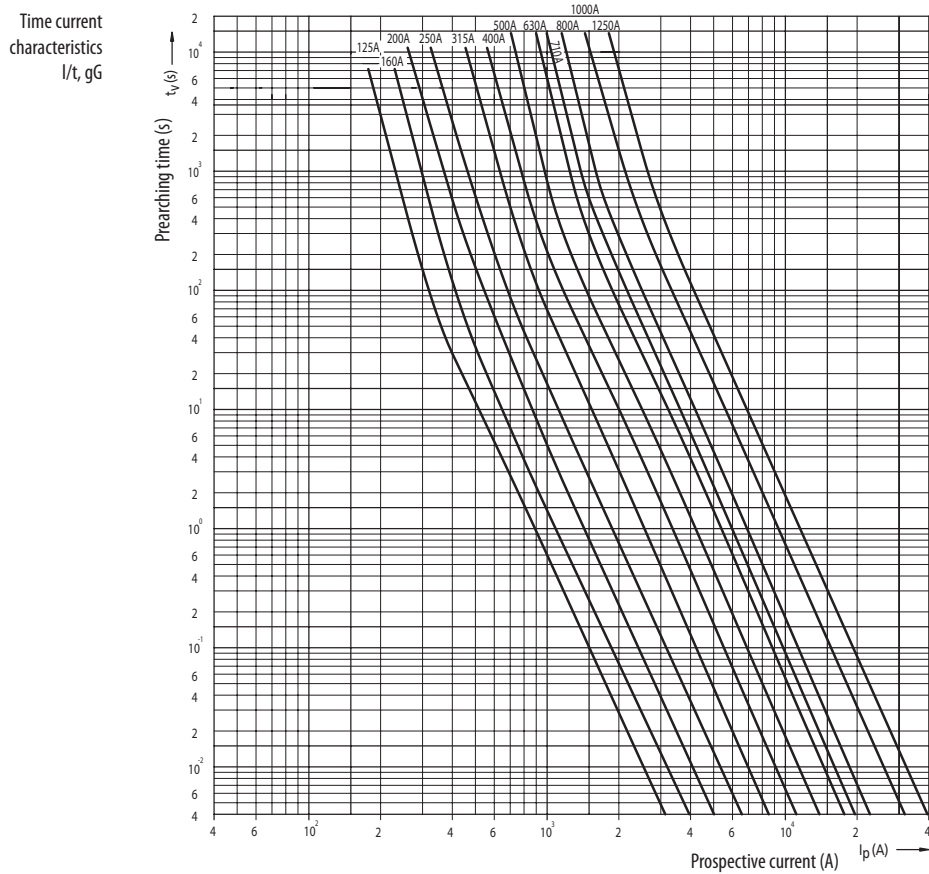
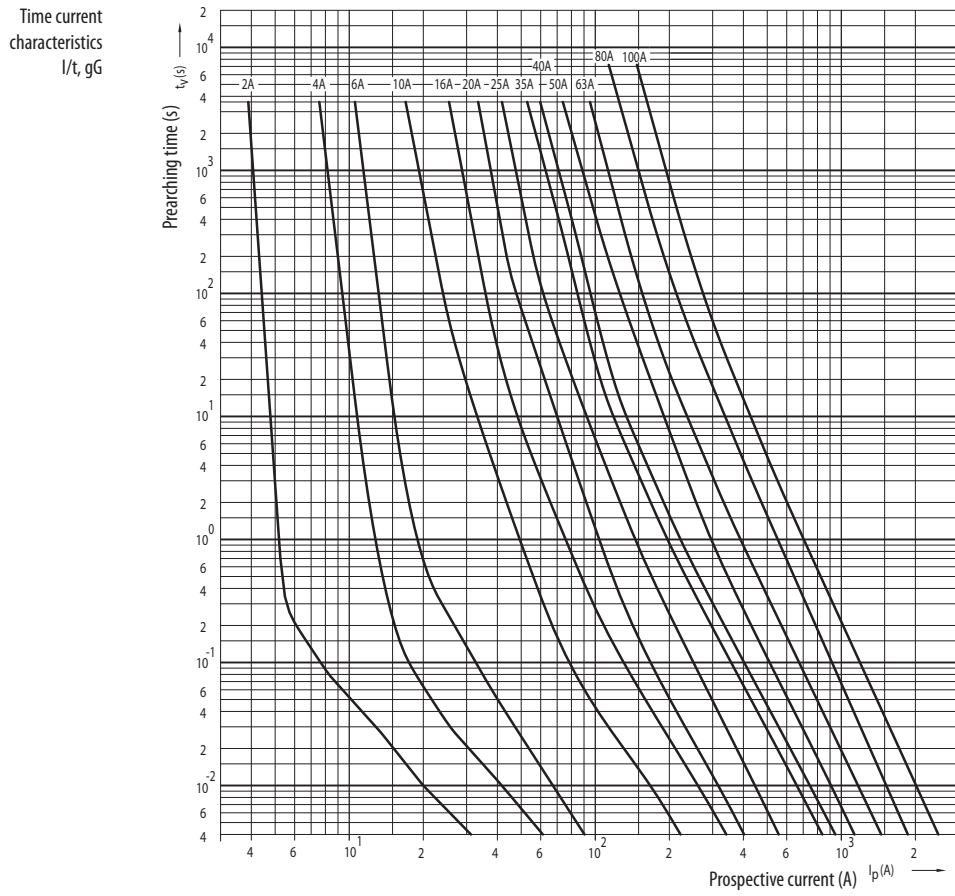

Time current characteristics I/t, gG (nonstandard rated currents)

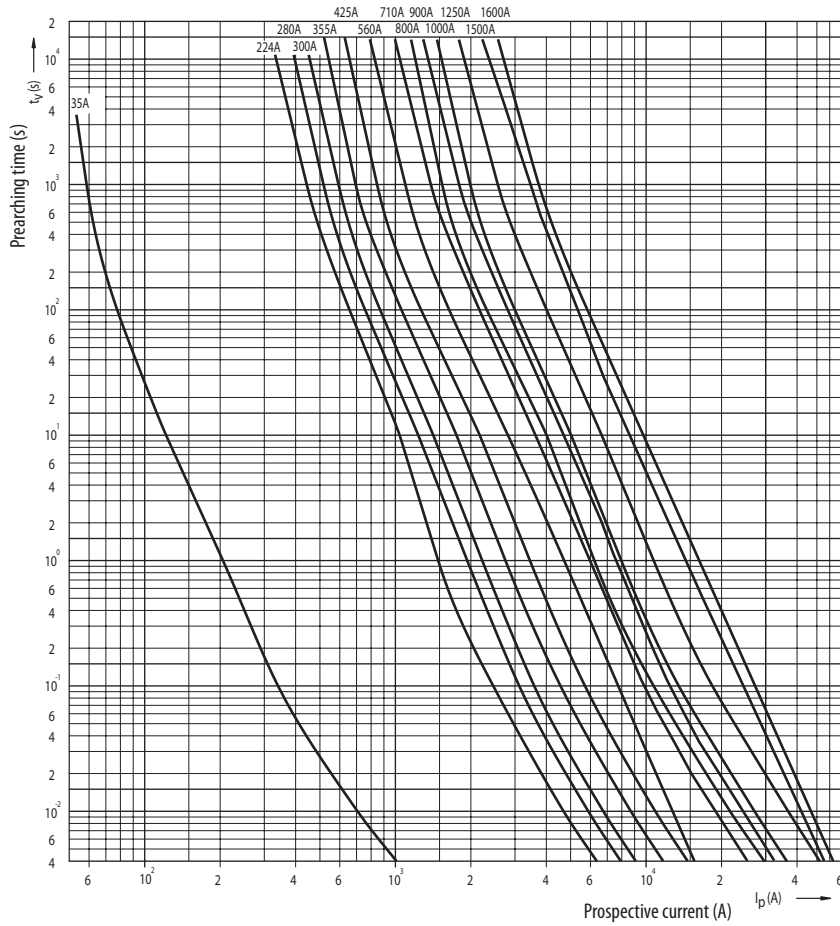

Cut-off current characteristics

