

REVISION RECORD

REV	ECN	DESCRIPTION	DRFT	DATE

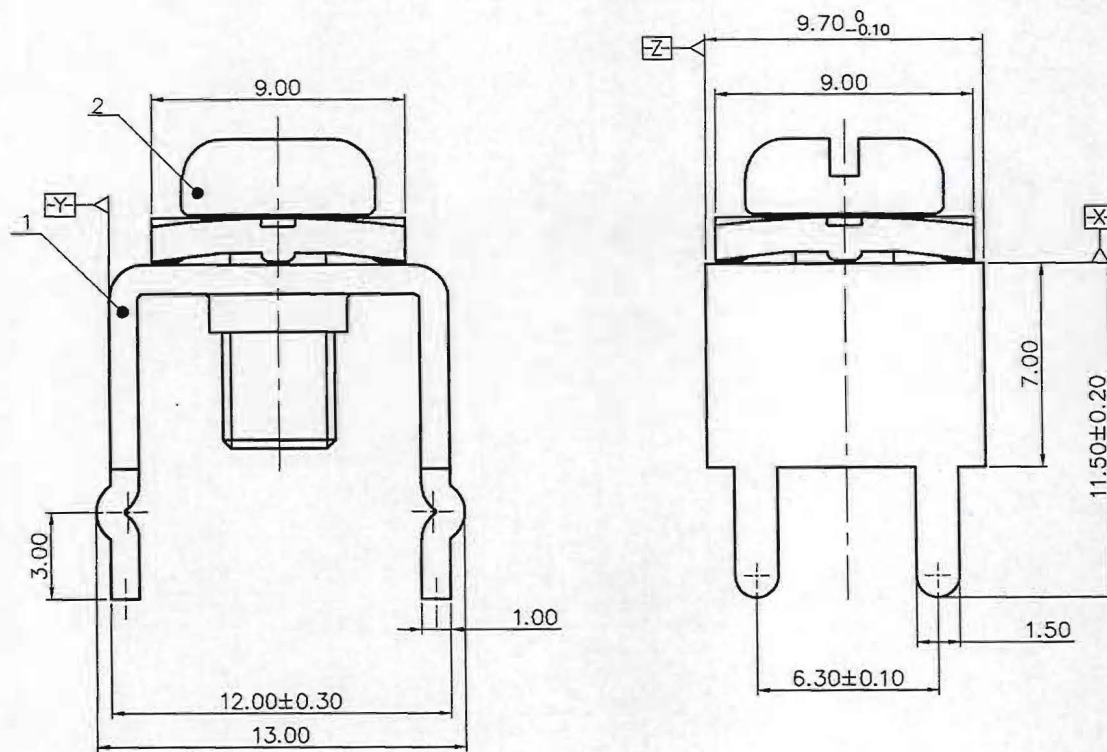

NOTES:

- Rated current : 15A
- Torque value : M4, 10.63Lb.in(1.2 N·m)
- Wire range : 18~14AWG
- Dimension shall be interpreted per ASME Y14.5-2009
- Undimensioned tolerances:

Pitch range in mm		Nominal dimension range in mm					0.1/10	
TO	Over TO	Over TO	TO	Over TO	Over TO	Over TO	∠	
6	10	24	30	60	100	150		
±0.15	±0.20	±0.30	±0.30	±0.50	±0.70	±1.00	±1.30	±2'

6.RoHS Compliance

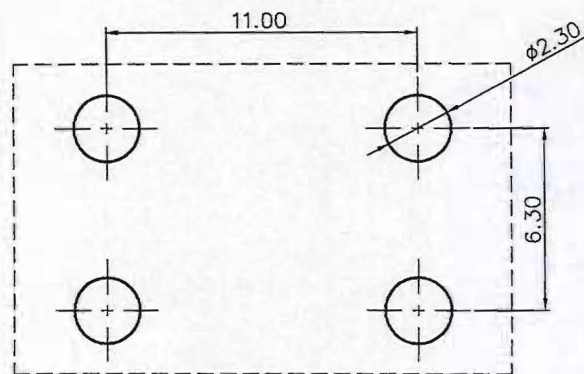

K13 - 00A (H)  
 (RoHS)  
 00A-(Standard)  
 (Series No.)



ITEM	NAME OF PART	MATERIAL	NOTES
2	Screw	Steel	M4/Ni Plated
1	Pin header	Copper alloy	Sn Plated

PART NO.:		宁波高松电子有限公司 NINGBO DEGSON ELECTRICAL CO., LTD	
APPD:	CHKD:	NAME: K13-00A(H)	
DRFT: zdz/2014.01.03		TITLE: CUSTOMER DRAWING	REV TO
THIRD ANGLE PROJECTION		DRAWING NO.: K13-C01	SHEET 1/1
		MM (INCH)	DO NOT SCALE DRAWING SCALE 1:1