

IP20 SELV     

Driver LCBI 25 W 700 mA basic phase-cut SR

basic series

Product description

- Dimmable via leading-edge and trailing-edge phase dimmer
- Output dimmed analogue (current amplitude)
- Dimming range typ. 5 to 100 % (depending on dimmer)
- Type of protection IP20
- Screw terminals
- Connecting cable, wire cross-section 0.5 – 2.5 mm²
- SELV
- 700 mA output current
- Output power 25 W
- Nominal life of 50,000 h (at ta max. 50 °C with a failure rate of max. 0.2 % per 1,000 h)
- 5-year guarantee

Properties

- Casing: polycarbonate, white
- Compact dimensions
- Overload protection
- Short-circuit protection
- No-load protection

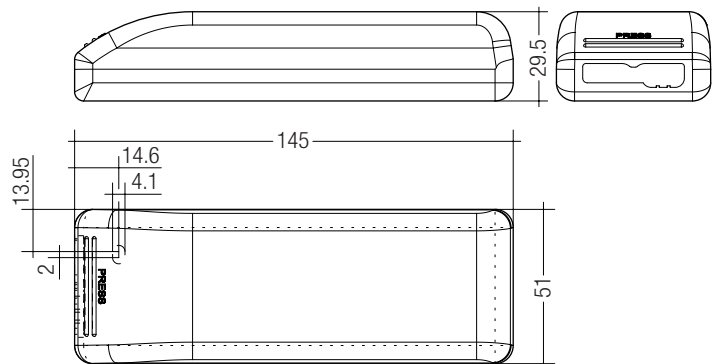

Technical data

Rated supply voltage	220 – 240 V
AC voltage range	198 – 264 V
Mains frequency	50 / 60 Hz
Typ. rated current (at 230 V, 50 Hz, full load)	0.13 A
λ at full load [®]	0.99
λ at min. load [®]	0.97
Output current tolerance at full load ^{®®®}	± 7.5 %
Typ. current ripple (at 230 V, 50 Hz, full load)	± 30 %
Starting time (at 230 V, 50 Hz, full load)	≤ 0.1 s
Turn off time (at 230 V, 50 Hz, full load)	≤ 0.1 s
Hold on time at power failure (output)	0 s
Ambient temperature ta	-25 ... +50 °C
Ambient temperature ta (at life-time 50,000 h)	50 °C
Max. casing temperature tc	75 °C
Storage temperature ts	-40 ... +85 °C
Life-time	up to 50,000 h
Dimensions L x W x H	145 x 51 x 29,5 mm

Ordering data

Type	Article number	Packaging, carton	Packaging, pallet	Weight per pc.
LCBI 25W 700mA basic phase-cut SR	89800307	10 pc(s).	600 pc(s).	0.115 kg



Standards, page 3

Wiring diagrams and installation examples, page 3

Specific technical data

Type	Efficiency at full load ^①	Efficiency at min. load ^①	Output current ^②	Max. repetitive output peak current at full load ^{③②}	Max. repetitive output peak current at min. load ^{③②}	Max. non-repetitive output peak current at full load ^{③②}	Max. non-repetitive output peak current at min. load ^{③②}	Max. forward voltage ^④	Min. forward voltage ^④	Max. output voltage ^④	Max. input power	Max. output power
LCBI 25W 700mA basic phase-cut SR	83 %	82 %	700 mA	950 mA	1,180 mA	950 mA	1,180 mA	35 V	17 V	39 V	30 W	25 W

^① Test result at 230 V, 50 Hz.

^② The trend between min. and full load is linear.

^③ Output current tolerance at min. load max. 22 %.

^④ At failure mode.

^⑤ Output current is mean value.

Standards

- EN 55015
- EN 61000-3-2
- EN 61000-3-3
- EN 61347-1
- EN 61347-2-13
- EN 61547
- EN 62384

Glow wire test according to IEC 60695-2-11

850 °C passed.

Overload protection

If the output voltage range is exceeded the LED Driver reduces the LED output current. After elimination of the overload the nominal operation is restored automatically.

Short-circuit behaviour

In case of a short circuit on the secondary side (LED) the LED Driver switches into hic-cup mode. After the removal of the short-circuit fault the LED Driver will recover automatically.

No-load operation

The LED Driver works in constant current mode. In no-load operation there is the max. output voltage at the output (see page 1).

Installation instructions

Note the requirements set out in the document
LED_driver_installation_advise.pdf
(<http://www.tridonic.com/com/en/technical-docs.asp>).

Hot plug-in or secondary switching of LEDs is not permitted and may cause a very high current to the LEDs.

Fixing conditions when using as independent Driver

Dry, acidfree, oilfree, fatfree. It is not allowed to exceed the maximum ambient temperature (ta) stated on the device. Minimum distances stated below are recommendations and depend on the actual luminaire.
Device is not suitable for fixing in corner.

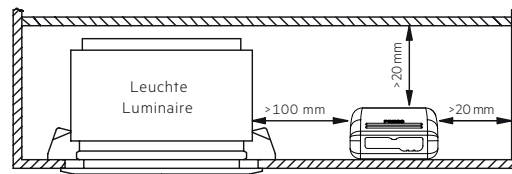

Maximum loading of automatic circuit breakers in relation to inrush current

Automatic circuit breaker type									Inrush current	
	C10	C13	C16	C20	B10	B13	B16	B20	I _{max}	Time
Installation Ø	1.5 mm ²	1.5 mm ²	1.5 mm ²	2.5 mm ²	1.5 mm ²	1.5 mm ²	1.5 mm ²	2.5 mm ²		
LCBI 25W 700mA basic phase-cut SR	30	39	48	60	30	39	48	60	2.5 A	60 µs

This are max. values calculated out of inrush current! Please consider not to exceed the maximum rated continuous current of the circuit breaker. Calculation uses typical values from ABB series S200 as a reference. Actual values may differ due to used circuit breaker types and installation environment.

Wiring diagram

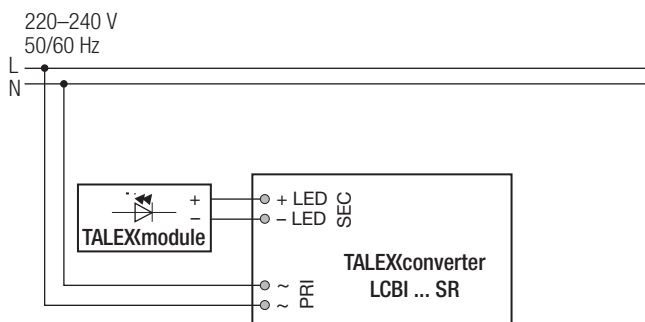

Wiring type and cross section

The wiring can be in stranded wires with ferrules or solid. For perfect function of the cage clamp terminals the strip length should be 4 – 5 mm for the input terminal.

The max. torque at the clamping screw (M3) is 0.2 Nm.

Input terminal (D2)

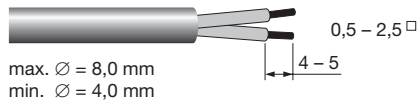

Output terminal (D1)

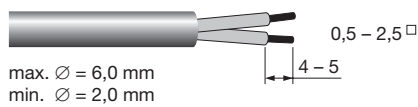

To get a proper working strain relief it is recommended that the cable jacket diameter of the side D2 is 2 mm bigger than the diameter of the side D1. (This can vary if the used cable jacket material varies from side D2 to D1 in pinching property).

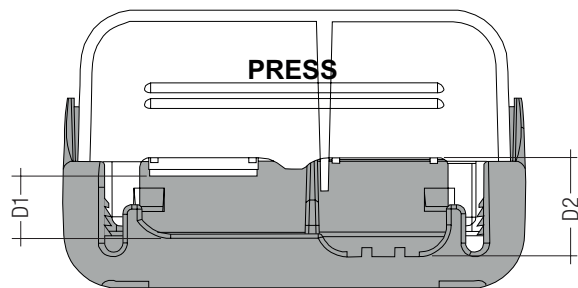

Depending on the used flaps of the terminal following cable jacket diameter difference between the side D2 and D1 terminals is recommended:

Side D1		Side D2		Difference D2 - D1
Housing bottom	Cover terminal	Cover terminal		
With flap	Without flap	With flap	Without flap	
x	-	x	-	3.5 mm
x	-	x	-	5.5 mm
x	-	-	x	3.5 mm
-	x	x	-	3.5 mm
-	x	-	x	1.5 mm
x	-	-	x	1.5 mm
-	x	x	-	1.5 mm
-	x	-	x	-0.5 mm

Wiring instructions

The secondary leads should be separated from the mains connections and wiring for good EMC performance.

Maximum lead length on secondary side is 2 m. For a good EMC performance keep the the LED wiring as short as possible.

The secondary wires (LED module) should be routed in parallel to ensure good EMC performance.

Through wiring is not possible.

To avoid the damage of the Driver, the wiring must be protected against short circuits to earth (sharp edged metal parts, metal cable clips, louver, etc.).

Insulation and electric strength testing of luminaires

Electronic devices can be damaged by high voltage. This has to be considered during the routine testing of the luminaires in production.

According to IEC 60598-1 Annex Q (informative only!) or ENEC 303-Annex A, each luminaire should be submitted to an insulation test with 500 V_{DC} for 1 second. This test voltage should be connected between the interconnected phase and neutral terminals and the earth terminal.

The insulation resistance must be at least 2 MΩ.

As an alternative, IEC 60598-1 Annex Q describes a test of the electrical strength with 1500 V_{AC} (Or 1.414 x 1500 V_{DC}). To avoid damage to the electronic devices this test must not be conducted.

Maximum number of switching cycles

All LED Driver are tested with 50,000 switching cycles.

The actually achieved number of switching cycles is significantly higher.

Additional information

Additional technical information at www.tridonic.com → Technical Data

Guarantee conditions at www.tridonic.com → Services

Life-time declarations are informative and represent no warranty claim. No warranty if device was opened.