

## Technical data

### Low voltage moulded case circuit breaker EB2

Product series	description	unit	condition	EB2 125			EB2 160	
				L	S	H	S	H
Model-type				L	S	H	S	H
Number of poles				3, 4			3, 4	
Nominal current ratings								
	$I_n$	(A)	50°C	20,32,50,			160	
				63,100,125				
Electrical characteristics								
Rated operational voltage	$U_e$	(V)	AC 50/60 Hz	690	690	690	690	690
			DC	250	250	250	250	250
Rated insulation voltage	$U_i$	(V)		800	800	800	800	800
Rated impulse withstand voltage	$U_{imp}$	(kV)		8	8	8	8	8
Ultimate breaking capacity (IEC, JIS, AS/NZS)	$I_{cu}$	(kA)	690V AC	-	6	6	7.5	7.5
			525V AC	8	22	25	25	25
			440V AC	15	25	50	25	50
			400/415V AC	25	36	65	36	65
			220/240V AC	35	50	85	65	85
			250V DC	25	25	40	40	40
Service breaking capacity (IEC, JIS, AS/NZS)	$I_{cs}$	(kA)	690V AC	-	6	6	7.5	7.5
			525V AC	6	22	22	25	25
			440V AC	12	25	25	25	25
			400/415V AC	19	36/30	36/33	36	36
			220/240V AC	27	50	85	65	85
			250V DC	19	19	40	40	40
Rated breaking capacity (NEMA)		(kA)	480V AC	8	22	25	22	25
			240VAC	35	50	85	65	85
Protection								
Adjustable thermal, adjustable magnetic				■	■		■	
Fixed thermal, fixed magnetic				■				
Microprocessor								
Utilisation category				A	A		A	
Installation								
Front connection				■	■		■	
Attached flat bar				•	•		•	
Solderless terminal (cable clamp)				•	•		•	
Rear connection				•	•		•	
Plug-in				•	•		•	
Draw-out				-	-		-	
DIN rail mounting				•	•		-	
Dimensions	h	(mm)		155	155		165	
	w	(mm)	3 pole	90	90		105	
			4 pole	120	120		140	
d	(mm)		68	68		68		
Weight	W	(kg)	3 pole	1.1	1.1		1.5	
			4 pole	1.4	1.4		1.9	
Operation								
Direct Opening Action				■	■		■	
Toggle operation				■	■		■	
Variable depth / direct mount operating handle				•	•		•	
Motor operator				•	•		•	
Endurance	Electrical	cycles	415V AC	30000	30000		20000	
	Mechanical	cycles		30000	30000		30000	
Standards	IEC 60947-2, EN 60947-2							

■ Standard • Optional - Not Available

Product series	description	unit	condition	EB2 250			EB2 250	
Model-type				L	S	H	LE	E
Number of poles				3, 4			3, 4	
Nominal current ratings								
	$I_n$	(A)	50°C	200, 250			40, 125, 160, 250	
Electrical characteristics								
Rated operational voltage	$U_e$	(V)	AC 50/60 Hz	690	690	690	690	690
			DC	250	250	250	-	-
Rated insulation voltage	$U_i$	(V)		800	800	800	800	800
Rated impulse withstand voltage	$U_{imp}$	(kV)		8	8	8	8	8
Ultimate breaking capacity (IEC, JIS, AS/NZS)	$I_{cu}$	(kA)	690V AC	-	7.5	7.5	7.5	20
			525V AC	10	25	25	25	35
			440V AC	15	25	50	25	50
			400/415V AC	25	36	65	36	70
			220/240V AC	35	65	85	65	125
			250V DC	25	40	40	-	-
Service breaking capacity (IEC, JIS, AS/NZS)	$I_{cs}$	(kA)	690V AC	-	7.5	7.5	7.5	15
			525V AC	7.5	25	25	25	35
			440V AC	12	25	25	25	50
			400/415V AC	19	36	36	36	70
			220/240V AC	27	65	85	65	125
			250V DC	19	40	40	-	-
Rated breaking capacity (NEMA)		(kA)	480V AC	10	22	25	25	35
			240VAC	35	65	85	65	125
Rated short-time withstand current	$I_{cw}$	(kA)	0.3 s	-	-	-	-	
Protection								
Adjustable thermal, adjustable magnetic				■	■	-	-	
Fixed thermal, fixed magnetic						-	-	
Microprocessor						■	■	
Utilisation category				A	A	A	A	
Installation								
Front connection				■	■	■	■	
Attached flat bar				•	•	•	•	
Solderless terminal (cable clamp)				•	•	•	•	
Rear connection				•	•	•	•	
Plug-in				•	•	•	•	
Draw-out				-	-	-	-	
DIN rail mounting				-	-	-	-	
Dimensions	h	(mm)		165	165	165	165	
			w	(mm)	3 pole	105	105	105
	d	(mm)	4 pole	140	140	140	140	
				68	68	103	103	
Weight	W	(kg)	3 pole	1.5	1.5	2.3	2.5	
			4 pole	1.9	1.9	3.1	3.3	
Operation								
Direct Opening Action				■	■	■	■	
Toggle operation				■	■	■	■	
Variable depth / direct mount operating handle				•	•	•	•	
Motor operator				•	•	•	•	
Endurance	Electrical	cycles	415V AC	10000	10000	10000	10000	
				30000	30000	30000	30000	
Standards				IEC 60947-2, EN 60947-2				

■ Standard • Optional - Not Available

## Technical data

Product series	description	unit	condition	EB2 400		EB2 400		EB2 630		
Model-type				L	S	E, LCD	HLCD	LE	E	HE
Number of poles				3,4	3,4	3,4	4	3,4	3,4	3,4
Nominal current ratings										
	$I_n$	(A)	50°C	250,400	250,400	250,400		630	630	630
Electrical characteristics										
Rated operational voltage	$U_e$	(V)	AC 50/60 Hz	525	690	690	690	690*	690*	690*
			DC	250	250	-	-	-	-	-
Rated insulation voltage	$U_i$	(V)		800	800	800	800	800	800	800
Rated impulse withstand voltage	$U_{imp}$	(kV)		8	8	8	8	8	8	8
Ultimate breaking capacity (IEC, JIS, AS/NZS)										
	$I_{cu}$	(kA)	690V AC	-	20	20	20	10*	20*	20*
			525V AC	15	30	30	30	15	30	30
			440V AC	22	45	45	65	25	45	65
			400/415V AC	25	50	50	70	36	50	70
			220/240V AC	35	85	85	100	50	85	100
			250V DC	25	40	-	-	-	-	-
Service breaking capacity (IEC, JIS, AS/NZS)										
	$I_{cs}$	(kA)	690V AC	-	15	15	15	10*	15*	15*
			525V AC	15	30	30	30	15	30	30
			440V AC	22	45	45	50	25	45	50
			400/415V AC	25	50	50	50	36	50	50
			220/240V AC	35	85	85	85	50	85	85
			250V DC	19	40	-	-	-	-	-
Rated breaking capacity (NEMA)										
		(kA)	480V AC	15	25	25	30	15	25	30
			240VAC	35	85	85	100	50	85	100
Rated short-time withstand current	$I_{cw}$	(kA)	0.3 s	-	-	5	5	-	-	-
Protection										
Adjustable thermal, adjustable magnetic				■	■					
Fixed thermal, fixed magnetic										
Microprocessor						■	■	■	■	■
Utilisation category				A	A	B	B	A	A	A
Installation										
Front connection				■	■	■	■	■	■	■
Attached flat bar				•	•	•	•	•	•	•
Solderless terminal (cable clamp)				•	•	•	•	-	-	-
Rear connection				•	•	•	•	-	-	-
Plug-in				•	•	•	•	-	-	-
Draw-out				•	•	•	•	-	-	-
DIN rail mounting				-	-	-	-	-	-	-
Dimensions										
	h	(mm)		260	260	260	260	260	260	260
	w	(mm)	3 pole	140	140	140	-	140	140	140
		(mm)	4 pole	185	185	185	185	185	185	185
	d	(mm)		103	103	103	103	103	103	103
Weight										
	W	(kg)	3 pole	4.2	4.2	4.3	-	5.0	5.0	5.0
			4 pole	5.6	5.6	5.7	5.7	6.5	6.5	6.5
Operation										
Direct Opening Action				■	■	■	■	■	■	■
Toggle operation				■	■	■	■	■	■	■
Variable depth / direct mount operating handle				•	•	•	•	•	•	•
Motor operator				•	•	•	•	•	•	•
Endurance										
	Electrical	cycles	415V AC	4500	4500	4500	4500	4500	4500	4500
	Mechanical	cycles		15000	15000	15000	15000	15000	15000	15000
Standards										
IEC 60947-2, EN 60947-2										

■ Standard • Optional - Not Available  
 \* MCCB can not be used in IT system at this voltage

Product series	description	unit	condition	EB2 800			EB2 800			EB2 1000		EB2 1250		EB2 1600	
Model-type				L	S	H	LE	E	HE	LE	E	LE	E	LE	E
Number of poles				3,4	3,4	3,4	3,4	3,4	3,4	3,4	3,4	3,4	3,4	3,4	3,4
Nominal current ratings															
	I <sub>n</sub>	(A)	50°C	630, 800	630, 800	630, 800	800	800	800	1000	1000	1250	1250	1600	1600
Electrical characteristics															
Rated operational voltage	U <sub>e</sub>	(V)	AC 50/60 Hz	690	690	690	690	690	690	690	690	690	690	690	690
			DC	250	250	250	-	-	-	-	-	-	-	-	-
Rated insulation voltage	U <sub>i</sub>	(V)		800	800	800	800	800	800	800	800	800	800	800	800
Rated impulse withstand voltage	U <sub>imp</sub>	(kV)		8	8	8	8	8	8	8	8	8	8	8	8
Ultimate breaking capacity (IEC, JIS, AS/NZS)	I <sub>cu</sub>	(kA)	690V AC	10*	20*	25*	20*	25*	25*	20*	25*	20*	25*	20*	45*
			525V AC	15*	30	45	30	35	40	30	45	30	45	30	65
			440V AC	30	50	65	50	65	125	45	65	45	65	45	85
			400/415V AC	36	50	70	50	70	125	50	70	50	70	50	100/85
			220/240V AC	50	85	100	85	100	150	85	100	85	100	85	125
			250V DC	50	50	50	-	-	-	-	-	-	-	-	-
Service breaking capacity (IEC, JIS, AS/NZS)	I <sub>cs</sub>	(kA)	690V AC	10*	20*	20*	20*	20*	20*	15*	20*	15*	20*	15*	34*
			525V AC	15*	30	34	30	30	34	23	34	23	34	23	50
			440V AC	30	50	50	50	50	94	34	50	34	50	34	65
			400/415V AC	36	50	50	50	50	94	38	50	38	50	38	75/65
			220/240V AC	50	85	75	85	75	150	65	75	65	75	65	94
			250V DC	50	50	50	-	-	-	-	-	-	-	-	-
Rated breaking capacity (NEMA)		(kA)	480V AC	15	30	45	30	35	40	30	45	30	45	30	65
			240V AC	50	85	100	85	100	150	85	100	85	100	85	125
Rated short-time withstand current	I <sub>cw</sub>	(kA)	0,3 sec	-	-	-	10	10	10	-	-	15	15	20	20
Protection															
Adjustable thermal, adjustable magnetic				■	■	■	-	-	-	-	-	-	-	-	-
Fixed thermal, fixed magnetic				-	-	-	-	-	-	-	-	-	-	-	-
Microprocessor				-	-	-	■	■	■	■	■	■	■	■	■
Utilisation category				A	A	A	B	B	B	A	A	B	B	B	B
Installation															
Front connection				■	■	■	■	■	-	-	-	-	-	-	-
Attached flat bar				•	•	•	•	•	■	■	■	■	■	■	■
Solderless terminal (cable clamp)				•	•	•	-	-	-	•	-	-	-	-	-
Rear connection				•	•	•	-	-	•	•	-	-	-	•	•
Plug-in				•	•	•	-	-	•	-	-	-	-	-	-
Draw-out				-	-	-	-	-	-	-	-	-	-	-	-
DIN rail mounting				-	-	-	-	-	-	-	-	-	-	-	-
Dimensions	h	(mm)		273	273	273	273	273	273	273	273	370	370	370	370
	w	(mm)	3 pole	210	210	210	210	210	210	210	210	210	210	210	210
		(mm)	4 pole	280	280	280	280	280	280	280	280	280	280	280	280
	d	(mm)		103	103	103	103	103	140	103	103	120	120	140	140
Weight	W	(kg)	3 pole	8,5	8,5	8,5	9,1	9,1	12,3	11	11	19,8	19,8	27	27
			4 pole	11,5	11,5	11,5	12,3	12,3	14,8	14,8	14,8	25	25	35	35
Operation															
Direct Opening Action				■	■	■	■	■	■	■	■	■	■	■	■
Toggle operation				■	■	■	■	■	■	■	■	■	■	■	■
Variable depth / direct mount operating handle				•	•	•	•	•	•	•	•	•	•	•	•
Motor operator				•	•	•	•	•	•	•	•	•	•	•	•
Endurance	Electrical	cycles	690	4000	4000	4000	4000	4000	4000	4000	4000	4000	4000	2000	2000
	Mechanical	cycles		10000	10000	10000	10000	10000	10000	10000	10000	5000	5000	5000	5000
Standards	IEC 60947-2, EN 60947-2														

■ Standard • Optional - Not Available  
 \* MCCB can not be used in IT system at this voltage

## Technical data

Product series	description	unit	condition	EB2R	EB2R
Model-type				125L	250L
Number of Poles				3, 4	3, 4
Nominal current ratings					
	$I_n$	(A)	50°C	20, 32, 50	160, 250
				63, 100, 125	
Electrical characteristics					
Rated operational voltage	$U_e$	(V)	AC 50/60 Hz	525	525
Rated impulse withstand voltage	$U_{imp}$	(kV)		8	8
Ultimate breaking capacity (IEC, JIS, AS/NZS)	$I_{cu}$	(kA)	525V AC	8	10
			440V AC	15	15
			400/415V AC	25	25
			220/240V AC	35	35
Service breaking capacity (IEC, JIS, AS/NZS)	$I_{cs}$	(kA)	525V AC	6	7.5
			440V AC	12	12
			400/415V AC	19	19
			220/240V AC	27	27
Protection					
Adjustable thermal, adjustable magnetic				■	■
Residual current protection, Type A				■	■
Utilization category				A	A
Installation					
Front connection				■	■
Attached flat bar				•	•
Solderless terminal (cable clamp)				•	•
Rear connection				•	•
Plug-in				-	-
DIN rail mounting				•	-
Dimensions	h	(mm)		155	165
	w	(mm)	3 pole	90	105
			4 pole	120	140
	d	(mm)		68	68
Weight	W	(kg)	3 pole	1.1	1.5
			4 pole	1.4	1.9
Operation					
Direct Opening Action				■	■
Toggle operation				■	■
Variable depth / direct mount operating handle				•	•
Mechanical interlocks				-	-
Motor operator				•	•
Endurance	Electrical	cycles	440V AC	30000	30000
	Mechanical	cycles		30000	30000
Standards	IEC 60947-2, EN 60947-2				

■ Standard • Optional - Not Available

Product series	description	unit	condition	EB2 400		EB2 800	
Model-type				LF	SF	LF	LF
Number of poles				3	3, 4	3, 4	
Nominal current ratings							
	$I_n$	(A)	50°C	400 (45°C)	400 (45°C)	630 (45°C)	800 (45°C)
Electrical characteristics							
Rated operational voltage	$U_c$	(V)	AC 50/60 Hz	690	690	690	690
			DC	250	250	250	250
Rated insulation voltage	$U_i$	(V)		690	690	690	690
Rated impulse withstand voltage	$U_{imp}$	(kV)		8	8	8	8
Ultimate breaking capacity (IEC, JIS, AS/NZS)	$I_{cu}$	(kA)	3,817	10	15	10	10
			525V AC	15	22	15	15
			440V AC	22	30	30	30
			400/415V AC	25	36	36	36
			220/240V AC	35	50	50	50
			250V DC	35	40	50	50
Service breaking capacity (IEC, JIS, AS/NZS)	$I_{cs}$	(kA)	690V AC	10	15	10	10
			525V AC	15	22	15	15
			440V AC	22	30	30	30
			400/415V AC	25	36	36	36
			220/240V AC	35	50	50	50
			250V DC	35	40	50	50
Rated breaking capacity (NEMA)		(kA)	480V AC 240VAC				
Rated short-time withstand current							
Protection							
Fixed thermal, adjustable magnetic				-	■		
Fixed thermal, fixed magnetic				■		-	-
Microprocessor				-	-	-	-
Utilisation category				A	A	A	A
Installation							
Front connection				■	■	-	-
Attached flat bar				•	•	■	■
Solderless terminal (cable clamp)				•	•	•	•
Rear connection				•	•	•	•
Plug-in				•	•	•	•
Draw-out						-	-
DIN rail mounting				-	-	-	-
Dimensions	h	(mm)		260	260	273	273
		(mm)	3 pole	140	140	210	210
	w	(mm)	4 pole	-	185	280	280
		(mm)		103	103	103	103
Weight	W	(kg)	3 pole	4.2	4.2	8	8,5
			4 pole	-	5.6	11	11,5
Operation							
Direct Opening Action				■	■	■	■
Toggle operation				■	■	■	■
Variable depth / direct mount operating handle				•	•	•	•
Motor operator				•	•	•	•
Endurance	Electrical	cycles	415V AC	4500	4500	4000	4000
	Mechanical	cycles		15000	15000	10000	10000
Standards				IEC 60947-2, EN 60947-2			

■ Standard • Optional - Not Available

Technical data

## Low voltage switch disconnecter

Product series	description	unit	condition	ED2	ED2	ED2	ED2	ED2		
Model-type				125	160	250	400	630		
Number of Poles				3, 4	3, 4	3, 4	3, 4	3, 4		
Nominal current ratings										
	$I_n$	(A)		125	160	250	400	630		
Electrical characteristics										
Rated operational voltage	$U_e$	(V)	AC 50/60 Hz	690	690	690	690	690		
			DC	600	600	600	600	600		
Rated insulation voltage	$U_i$	(V)		800	800	800	800	800		
Rated impulse withstand voltage	$U_{imp}$	(kV)		8	8	8	8	8		
Rated short-circuit making capacity	$I_{cm}$	(kA peak)		3,6	6	6	9	9		
Rated short-time withstand current	$I_{cw}$	(kA rms)	0.3s	2	3	3	5	5		
			AC	AC-23A	AC-23A	AC-23A	AC-23A	AC-23A		
			DC	DC-22A	DC-22A	DC-22A	DC-22A	DC-22A		
Installation										
Front connection				■	■	■	■	■		
Attached flat bar				•	•	•	•	•		
Solderless terminal				•	•	•	•	•		
Rear connection				•	•	•	•	•		
Plug-in				•	•	•	•	•		
Draw-out				•	•	•	•	•		
DIN rail mounting				•	-	-	-	-		
Dimensions	h	(mm)		155	165	165	260	260		
			w	(mm)	3 pole	90	105	105	140	140
					4 pole	120	140	140	185	185
d	(mm)		68	68	68	103	103			
Weight	W	(kg)	3 pole	1.1	1.5	1.5	4.2	4.4		
			4 pole	1.4	1.9	1.9	5.6	5.8		
Operation										
Direct Opening Action				■	■					
Toggle operation				■	■					
Variable depth / direct mount operating handle				•	•					
Motor operator				•	•					
Endurance	Electrical	cycles	415V AC	30000	20000	10000	4500	4500		
	Mechanical	cycles		30000	30000	30000	15000	15000		
Standards	IEC 60947-2, EN 60947-2									

Product series	description	unit	condition	ED2	ED2	ED2		
Model-type				800	1250	1600		
Number of Poles				3, 4	3, 4	3, 4		
Nominal current ratings								
	$I_n$	(A)		800	1250	1600		
Electrical characteristics								
Rated operational voltage	$U_e$	(V)	AC 50/60 Hz	690	690	690		
			DC	600	600	600		
Rated insulation voltage	$U_i$	(V)		800	800	800		
Rated impulse withstand voltage	$U_{imp}$	(kV)		15	32	45		
Rated short-circuit making capacity	$I_{cm}$	(kA peak)		9,6	15	20		
Rated short-time withstand current	$I_{cw}$	(kA rms)	0.3sec.	2	3	3		
			AC	AC-23A	AC-23A	AC-23A		
			DC					
Installation								
Front connection				■	■	■		
Attached flat bar				•	•	•		
Solderless terminal				-	-	-		
Rear connection				-	-	-		
Plug-in				-	-	-		
Draw-out				-	-	-		
DIN rail mounting				-	-	-		
Dimensions	h	(mm)		273	370	370		
			w	(mm)	3 pole	210	210	210
					4 pole	280	280	280
d	(mm)		103	120	140			
Weight	W	(kg)	3 pole	8.5	18.2	24.9		
			4 pole	11.5	23.4	32.9		
Standards	IEC 60947-3, EN 60947-3							

# Thermal magnetic adjustments and characteristics

## Thermal adjustment

Low voltage moulded case circuit breakers have a wide thermal adjustment range, one of the largest on the market. The rated current 'I<sub>r</sub>' is continuously adjustable from 63% to 100% of this nominal current 'I<sub>n</sub>'. There are three main points of calibration marked at 63%, 80% and 100%.

## Magnetic adjustment

An adjustable magnetic characteristics allows short-circuit protection to be matched to the load and supply characteristics, for example motor inrush current or generator short-circuit current.

Time, current characteristics curves  
EB2 125

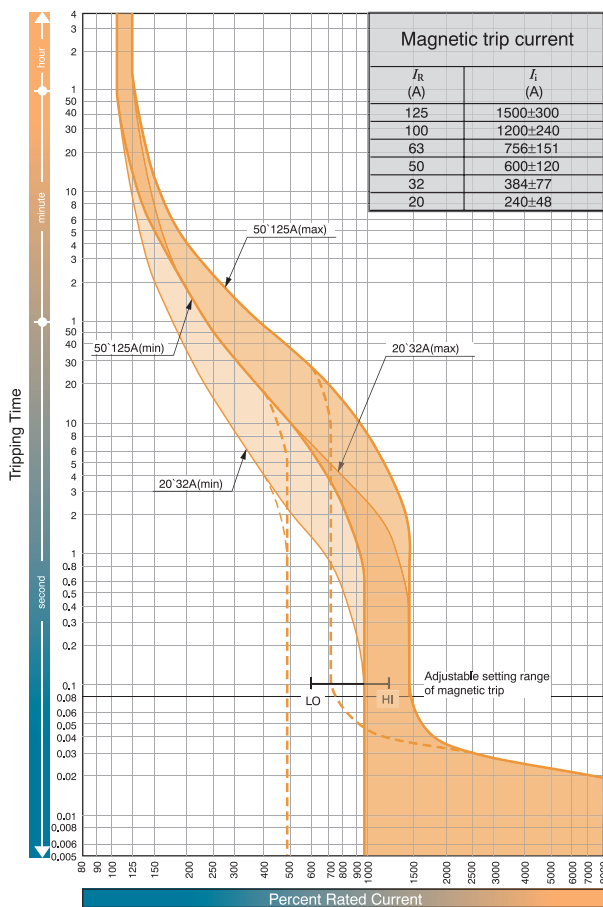

Time, current characteristics curves  
EB2 160 and EB2 250

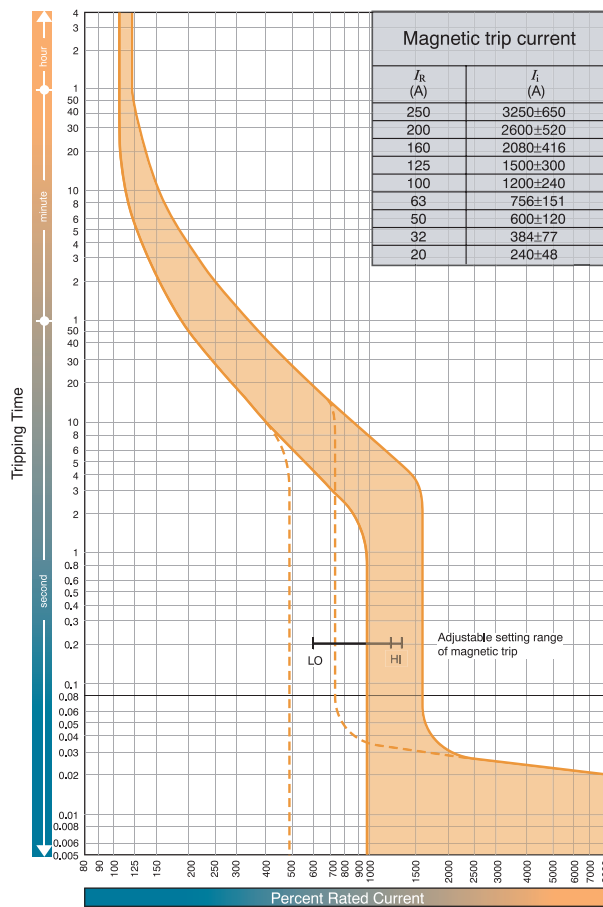

Ambient compensating curves

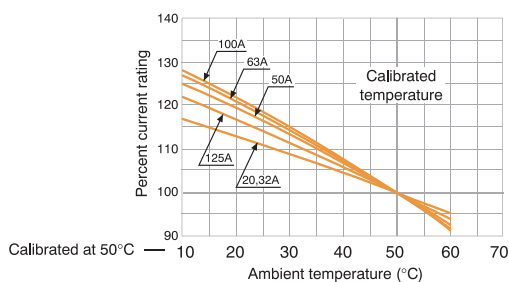

Ambient compensating curves

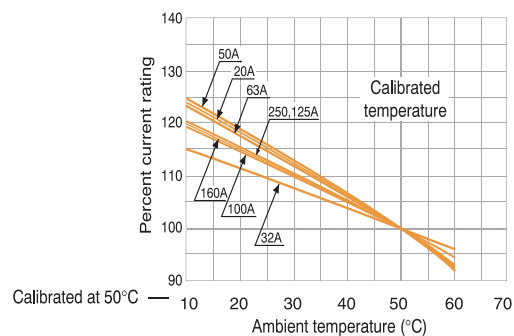



Technical data

Time, current characteristics curves  
EB2 400

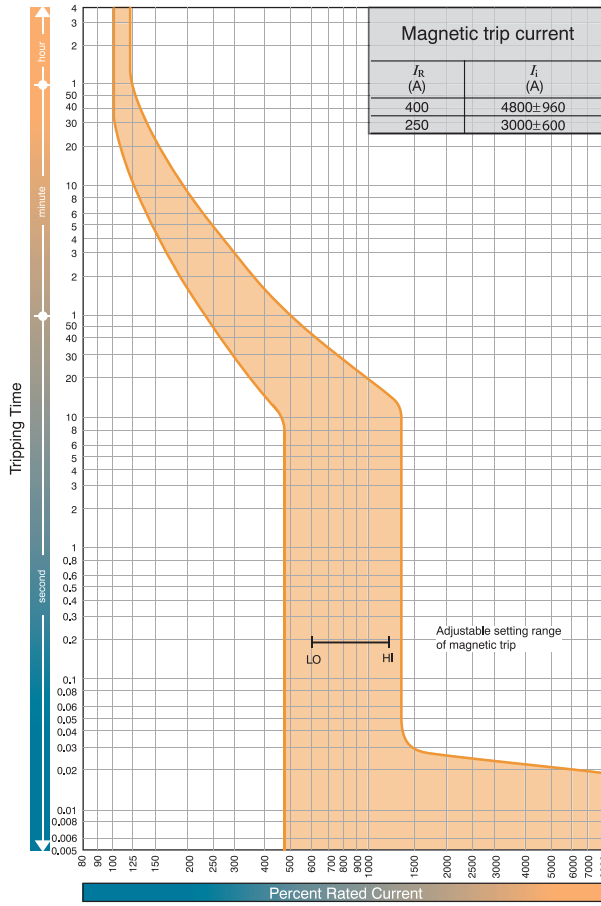

Time, current characteristics curves  
EB2 630 and EB2 800

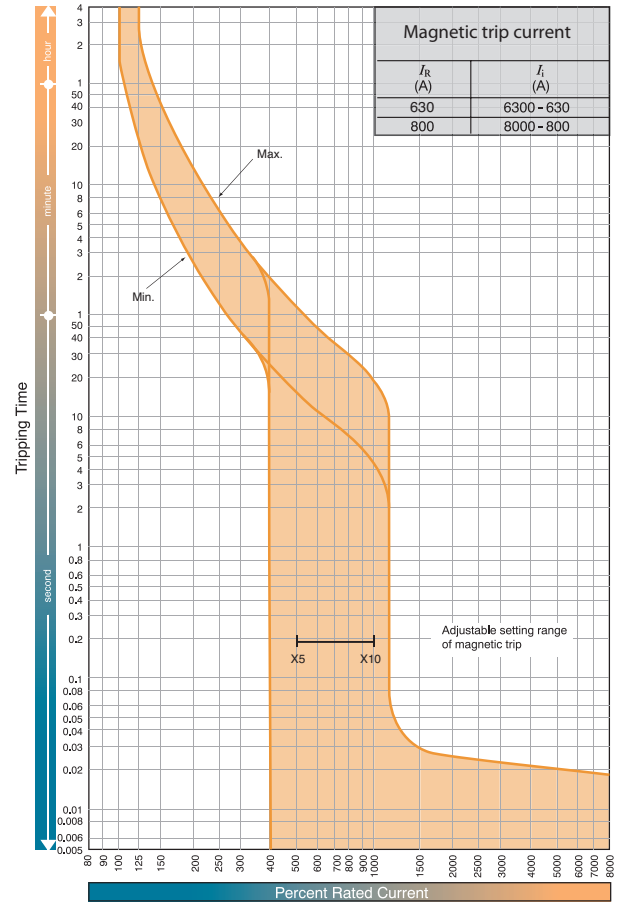

Ambient compensating curves

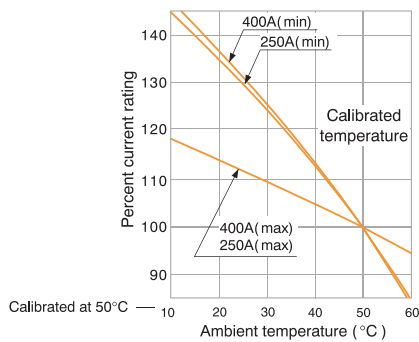

Ambient compensating curves

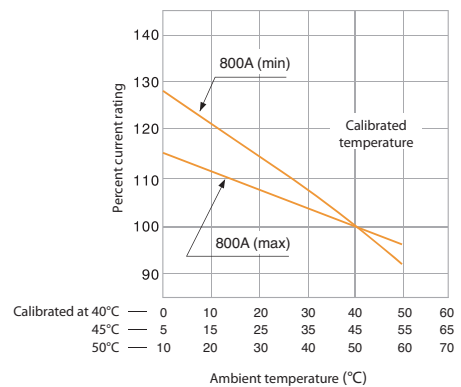

Special applications of thermal magnetic MCCBs

All standard thermal magnetic MCCBs are suitable for DC application up to 250 V DC.

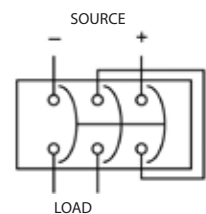

Time, current characteristics curves  
EB2 400 SF

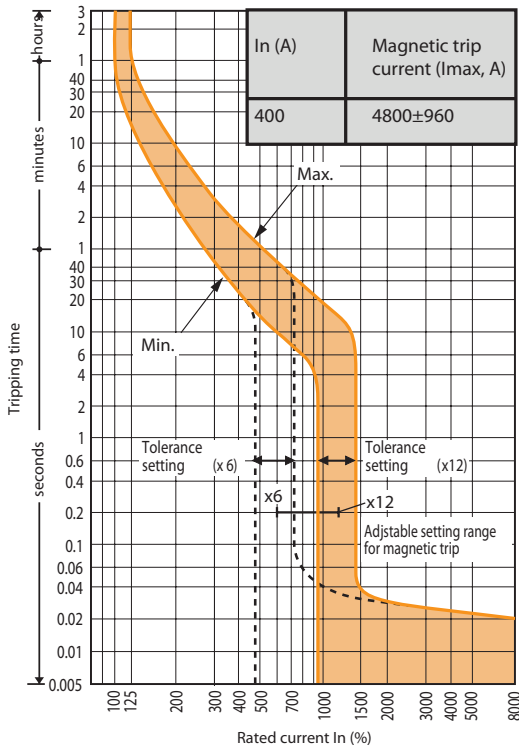

Time, current characteristics curves  
EB2 800/LF 630A

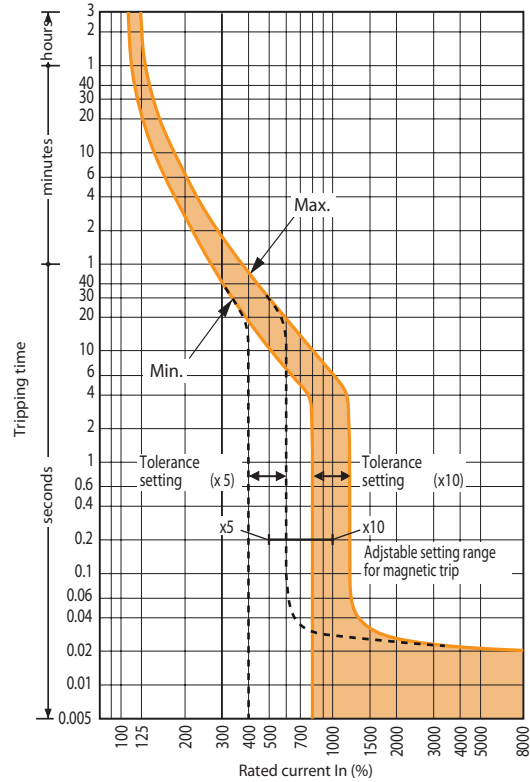

Time, current characteristics curves  
EB2 800/LF 800A

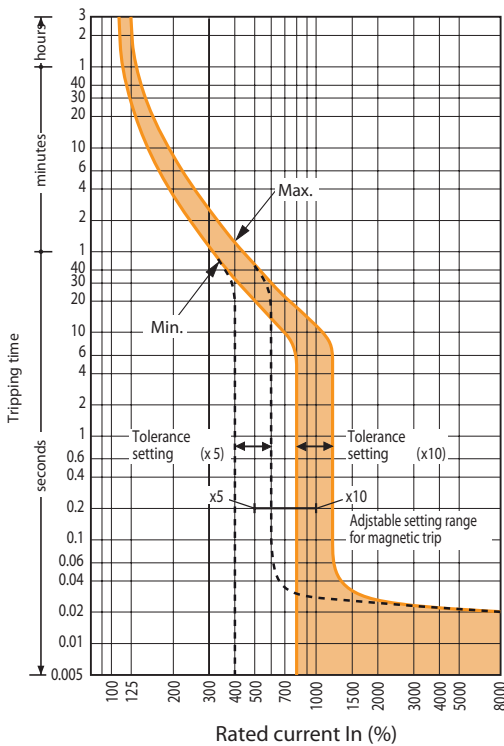

## Microprocessor based characteristics and adjustments EB2 series

Etibreak 2 MCCBs from 250A to 1600A frame sizes are available with electronic protection units. Current ratings,  $I_n$ , of 40A, 125A, 160A, 250A, 400A, 630A, 800A, 1000A, 1250A and 1600A are available. These offer great flexibility as their characteristics can be set to suit a wide range of application conditions. Overload protection can be set between 0.4 and 1.0 times  $I_n$ .

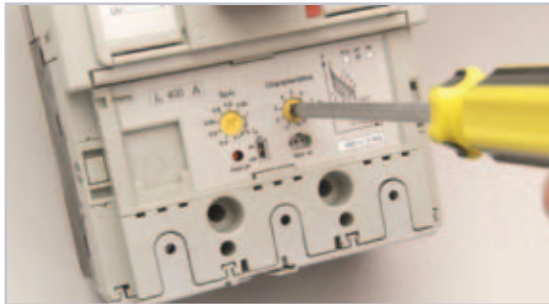

Selecting a Preset Characteristic for a 400A Etibreak 2 MCCB with Electronic Protection

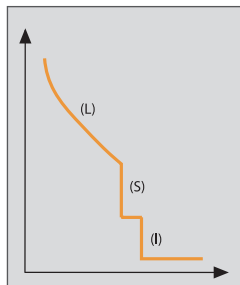

Electronic protection characteristic

Every Etibreak electronic protection unit includes overload protection (L), delayed short-circuit protection (S) and instantaneous protection (I) as standard.



### Adjustment dials

The left adjustment dial sets the rated current to match the conductor rating. The right adjustment dials select one of six on 630A models preset characteristics. The effects of the left adjustment dial (labelled  $I_n(A)$ ), and the right adjustment dial (labelled Characteristics) are detailed in the tables shown underneath each time/current graph.

### Tolerances of Characteristics

Characteristics		Tolerance
Long Time Delay (LTD)	$t_r$	+/- 20%
Short Time Delay (STD)	$I_{sd}$	+/- 15%
	$t_{sd}$	Total cleanig time +50ms, resettable time - 20ms
Instantaneous (INST)	$I_1$	+/- 20%

EB2 250 LE & E

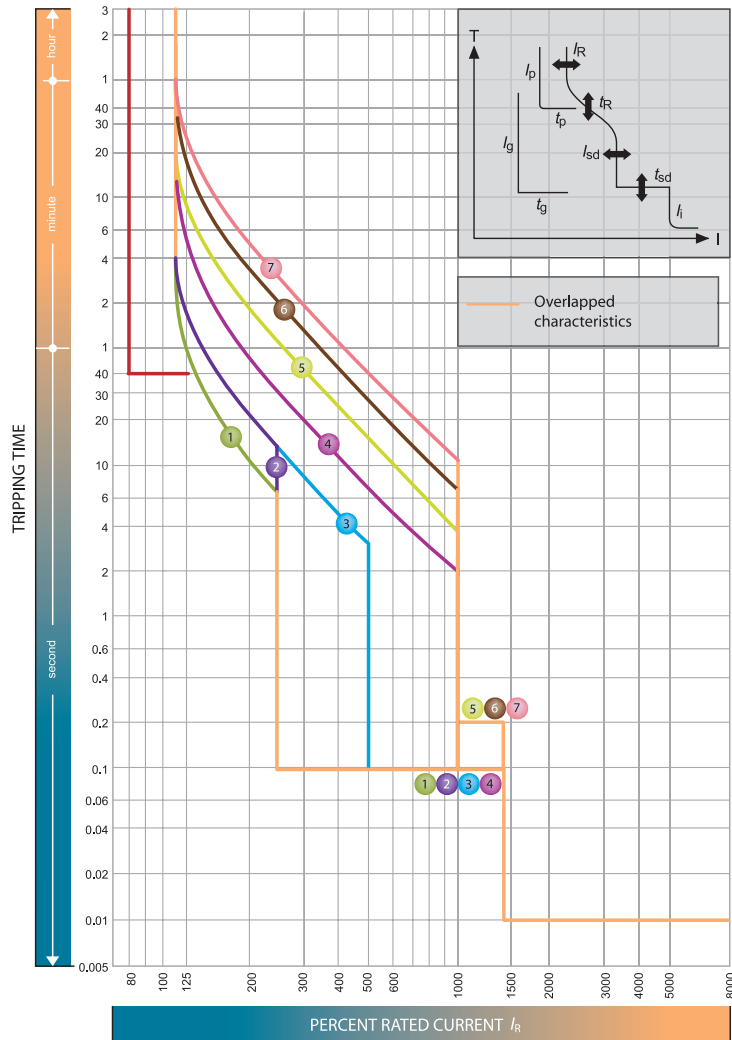

$I_n = 40, 125, 160, 250$

$I_n$ (A)									
LTD Pick-up current $I_R$	$xI_n$	0.4	0.5	0.63	0.8	0.9	0.95	1.0	

Standard	Characteristics		No.	1	2	3	4	5	6	7
	LTD	Index $t_R$	Index (s)	11	21	21	5	10	19	29
STD	Index $I_{sd}$	Index $xI_n$	at 200% $xI_n$			at 600% $xI_n$				
	Index $t_{sd}$	Index (s)	2.5			5		10		
INST	Index $I_i$	Index $xI_n$	0.1				0.2			
			14 (Max: 13 $xI_n$ ) Note (1)							

Note: (1)  $I_i$  max. = 12  $xI_n$ .

EB2 400 E, LCD, HLCD

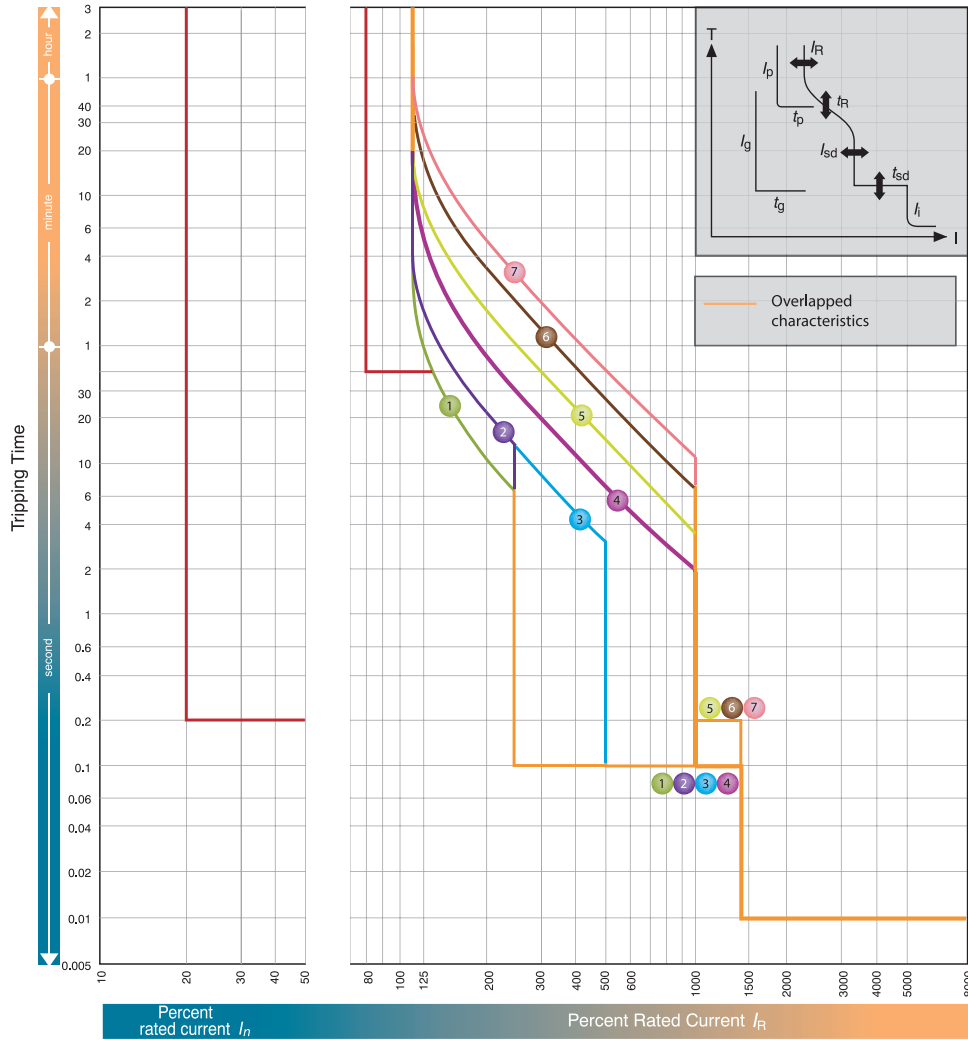

$I_n = 250, 400$

$I_R$ (A)									
LTD Pick-up current $I_R$	$xI_n$	0.4	0.5	0.63	0.8	0.9	0.95	1.0	

Standard	Characteristics		No.	1	2	3	4	5	6	7
	LTD	Index $t_R$	Index (s)	11	21	21	5	10	19	29
STD	Index $I_{sd}$	Index $xI_R$	at 200% $xI_R$			at 600% $xI_R$				
	Index $t_{sd}$	Index (s)	2.5	5	0.1			0.2		
INST	Index $I_i$	Index $xI_R$	14 (Max: 13 $xI_R$ ) Note (1)							

Note: (1)  $I_i$  max. = 13  $xI_n$ .

EB2 630 LE, E, LCD, HLCD

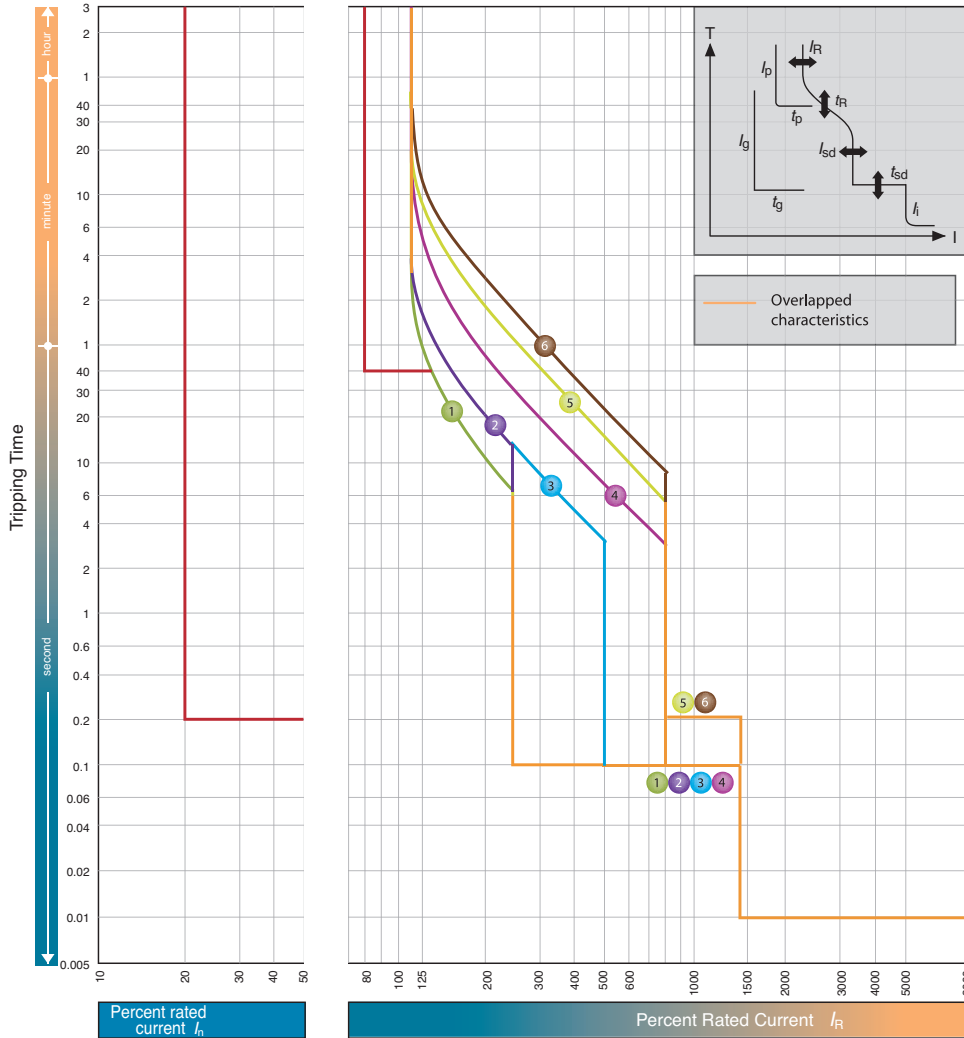

$I_n = 630A$

		$I_R$ (A)									
		LTD Pick-up current $I_R$	$xI_n$	0.4	0.5	0.63	0.8	0.85	0.9	0.95	1.0
Standard	LTD	Index $t_R$	Index (s)	11	21	21	5	10	16		
				at 200% $xI_n$			at 600% $xI_n$				
	STD	Index $I_{sd}$	Index $xI_n$	2.5		5		8			
		Index $t_{sd}$	Index (s)	0.1				0.2			
INST	Index $I_i$	Index $xI_n$	14 (Max: 10 $xI_n$ ) Note (1)								

Note: (1)  $I_i$  max. = 10  $xI_n$ .

EB2 800 LE, E, HE

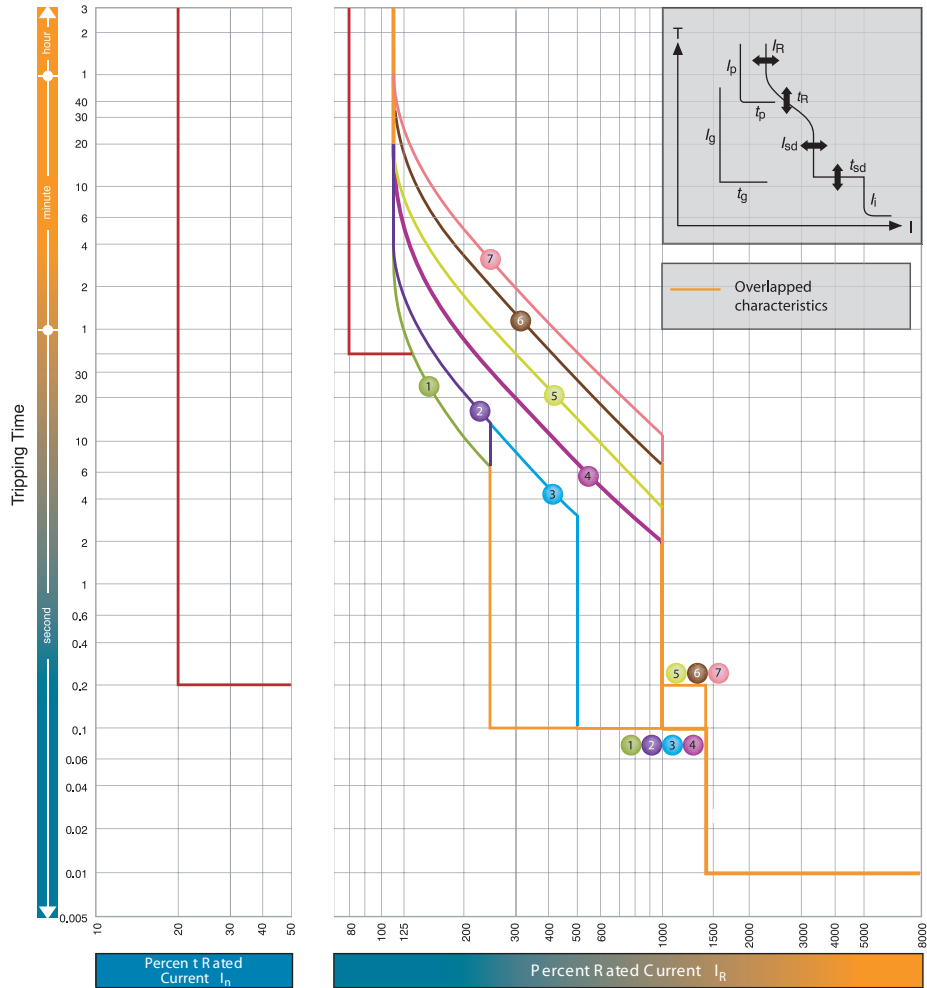

$I_n = 800$

$I_R$ (A)									
LTD Pick-up current $I_R$	$xI_n$	0.4	0.5	0.63	0.8	0.9	0.95	1.0	

	Characteristics		No.	1	2	3	4	5	6	7	
	Standard	LTD	Index $t_R$	Index (s)	11	21	21	5	10	19	29
			at 200% $xI_R$			at 600% $xI_R$					
STD		Index $I_{sd}$	Index $xI_R$	2.5		5		10			
		Index $t_{sd}$	Index (s)	0.1				0.2			
INST	Index $I_i$	Index $xI_R$	14 (Max: 12 $xI_R$ ) Note (1)								

Note: (1)  $I_i$  max. = 12  $xI_n$ .

EB2 1000 LE, E

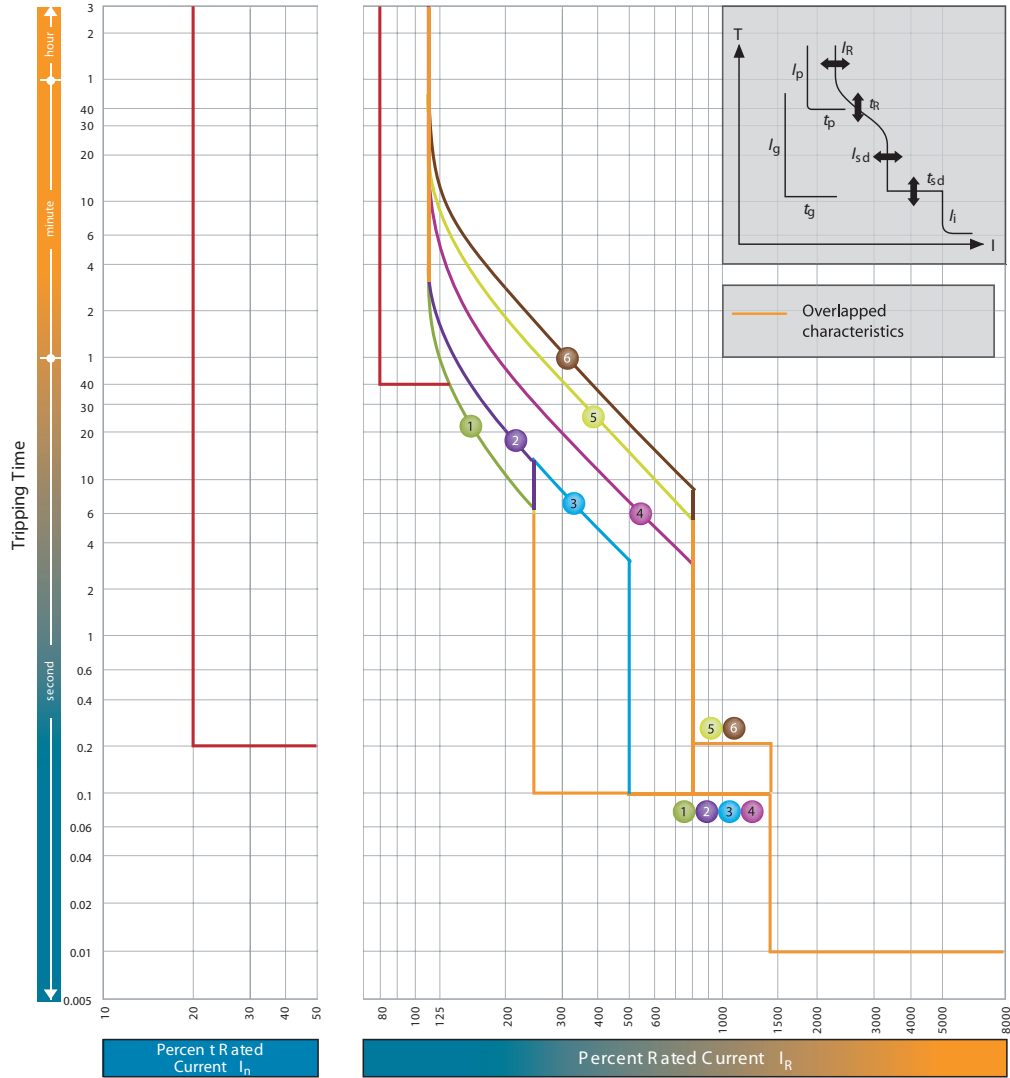

$I_n = 1000A$

		$I_R$ (A)									
		LTD Pick-up current $I_R$	$xI_n$	0.4	0.5	0.63	0.8	0.85	0.9	0.95	1.0
Standard	LTD	Index $t_R$	Index (s)	11	21	21	5	10	16		
				at 200% $xI_n$			at 600% $xI_n$				
	STD	Index $I_{sd}$	Index $xI_R$	2.5		5	8				
		Index $t_{sd}$	Index (s)	0.1					0.2		
INST	Index $I_{li}$	Index $xI_n$	14 (Max: 10 $xI_n$ ) Note (1)								

Note: (1)  $I_{li}$  max. = 10  $xI_n$ .



EB2 1250 LE, E

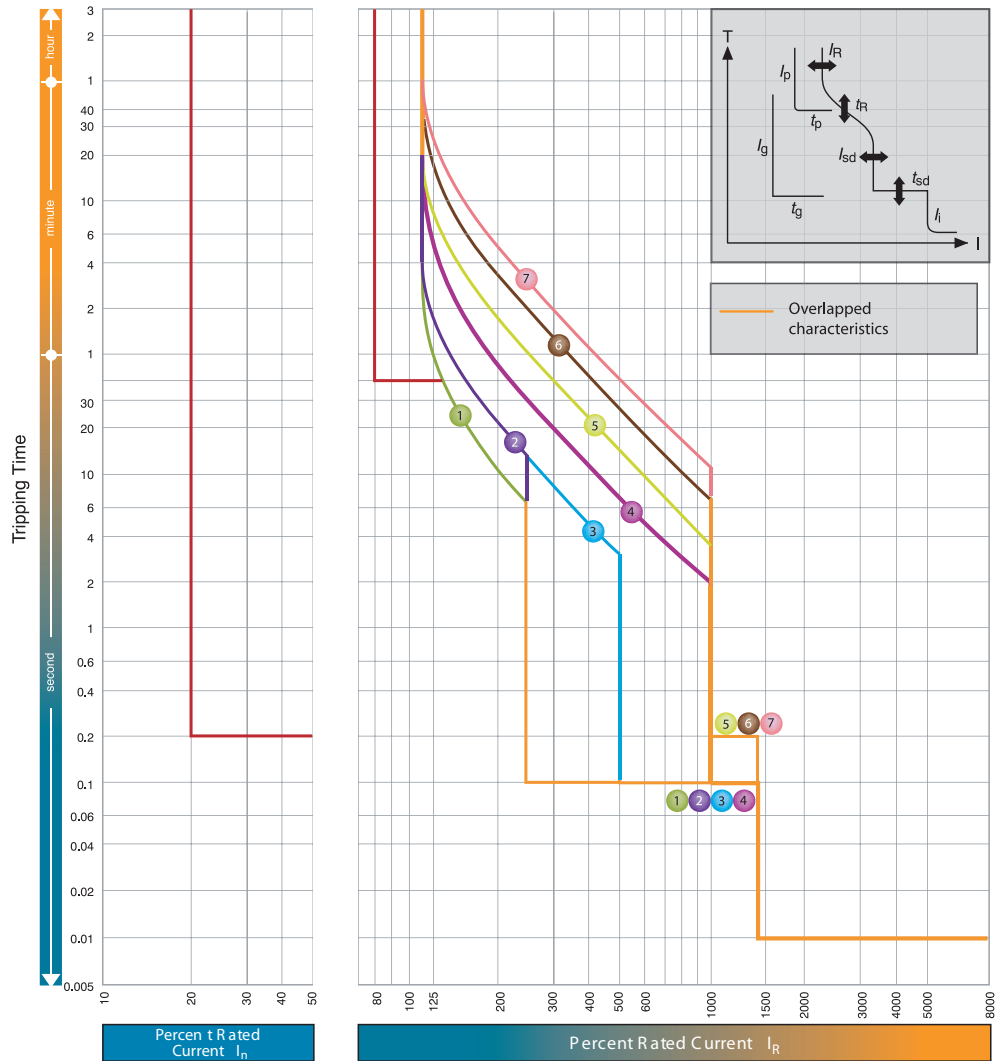

$I_n = 1250$

$I_R$ (A)									
LTD Pick-up current $I_R$	$xI_n$	0.4	0.5	0.63	0.8	0.9	0.95	1.0	

	Characteristics		No.	1	2	3	4	5	6	7	
	Standard	LTD		Index $t_R$	Index (s)	11	21	21	5	10	19
			at 200% $xI_R$			at 600% $xI_R$					
STD		Index $I_{sd}$	Index $xI_R$	2.5		5		10			
		Index $t_{sd}$	Index (s)	0.1				0.2			
INST	Index $I_i$	Index $xI_R$	14 (Max: 12 $xI_R$ ) Note (1)								

Note: (1)  $I_i$  max. = 12  $xI_n$ .

EB2 1600 LE, E

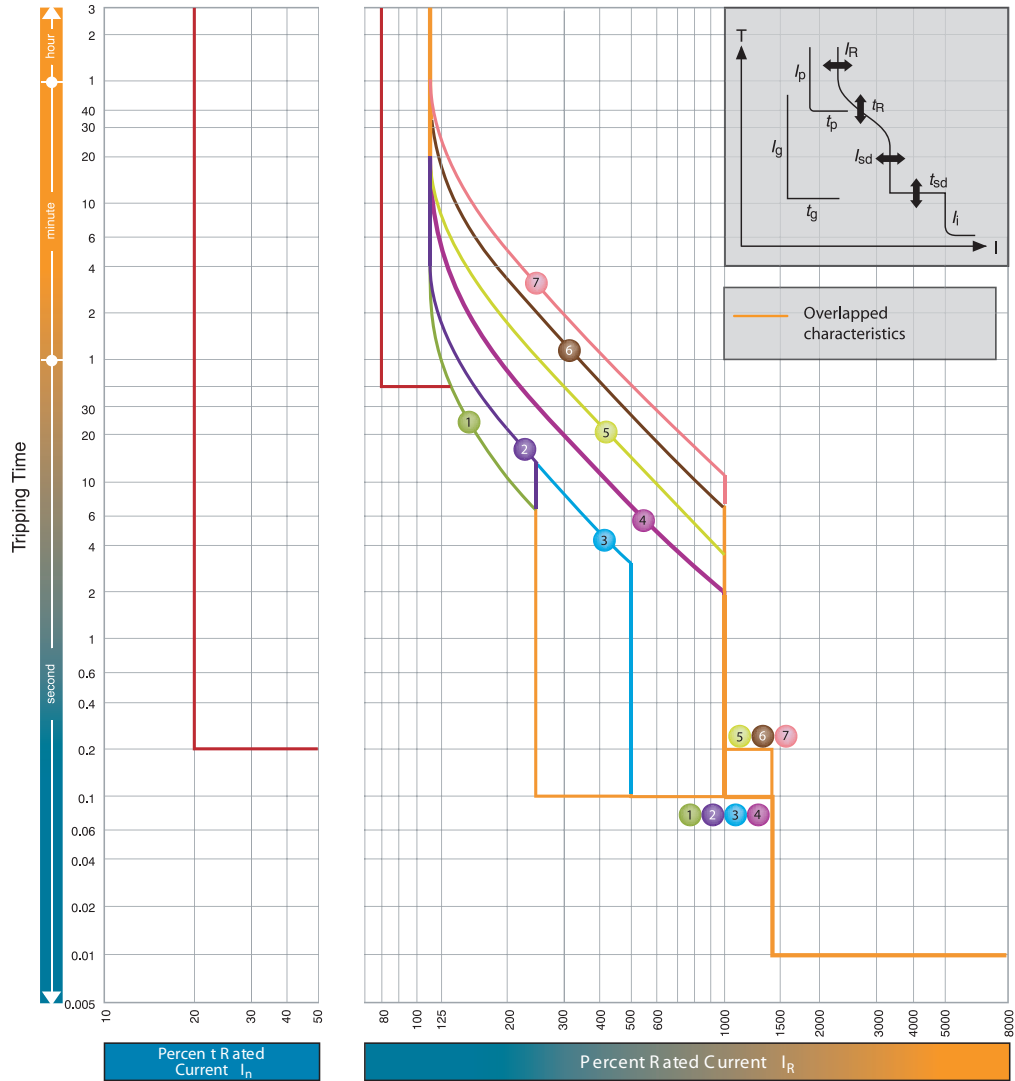

$I_n = 1600A$

		$I_n$ (A)								
		LTD Pick-up current $I_R$	$xI_n$	0.4	0.5	0.63	0.8	0.9	0.95	1.0
Standard	LTD	Index $t_r$	Index (s)	11	21	21	5	10	19	29
					at 200% $xI_n$			at 600% $xI_n$		
	STD	Index $I_{sd}$	Index $xI_R$	2.5		5		10		
		Index $t_{sd}$	Index (s)	0.1				0.2		
INST	Index $I_i$	Index $xI_n$	14 (Max: 12 $xI_n$ ) Note (1)							

Note: (1)  $I_i$  max. = 12  $xI_n$ .

### EB2R adjustments

Residual current  $I_{\Delta n}$  is the adjustable tripping threshold for earth leakage protection. It can be set between 30mA and 3A. Available settings are 30mA, 100mA, 300mA, 500mA, 1000mA and 3000mA. Available settings are shown below

Time delay  $\Delta t$  is introduced to the residual current (earth leakage) protection characteristic. Available settings are; INST, 60ms, 200ms, 400ms, 700ms and NT. INST means EB2R set to time delay 0 (max. actual tripping time is 40ms) NT means No trip (tripping time is 0) The maximum breaking time is shown in brackets. Note that  $I_{\Delta n}$  is set at 30mA,  $\Delta t$  defaults 0.

$I_n$  is the adjustable tripping threshold for overload protection. It can be set between 0,63 and 1,0 times  $I_n$ . Available  $I_n$  ratings are shown below

$I_i$  is the tripping threshold for short-circuit protection. It is fixed at the values shown below

Model	$I_{\Delta n}$	$\Delta t$ (ms)	$I_n$ (A)	$I_i$
EB2R 125	0.03, 0.1, 0.3, 0.5, 1, 3	0(40), 60(195), 200(365), 400(620), 700(950), NT ( $\infty$ )	20, 32, 50, 63, 100	$12 \times I_n$ (+/- 20%)
EB2R 125	0.03, 0.1, 0.3, 0.5, 1, 3	0(40), 60(195), 200(365), 400(620), 700(950), NT ( $\infty$ )	125	$10 \times I_n$ (+/- 20%)
EB2R 250	0.03, 0.1, 0.3, 0.5, 1, 3	0(40), 60(195), 200(365), 400(620), 700(950), NT ( $\infty$ )	160	$13 \times I_n$ (+/- 20%)
EB2R 250	0.03, 0.1, 0.3, 0.5, 1, 3	0(40), 60(195), 200(365), 400(620), 700(950), NT ( $\infty$ )	250	$10 \times I_n$ (+/- 20%)

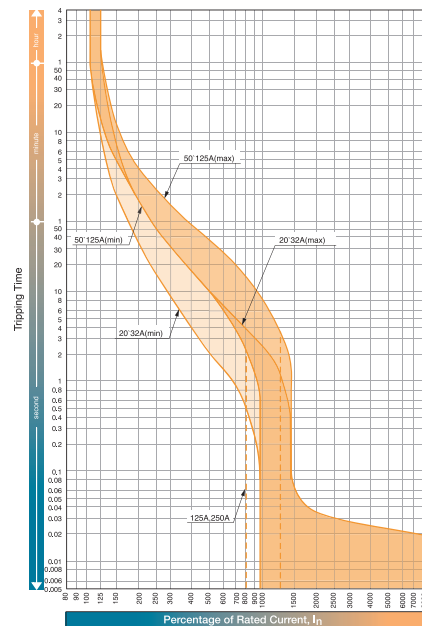
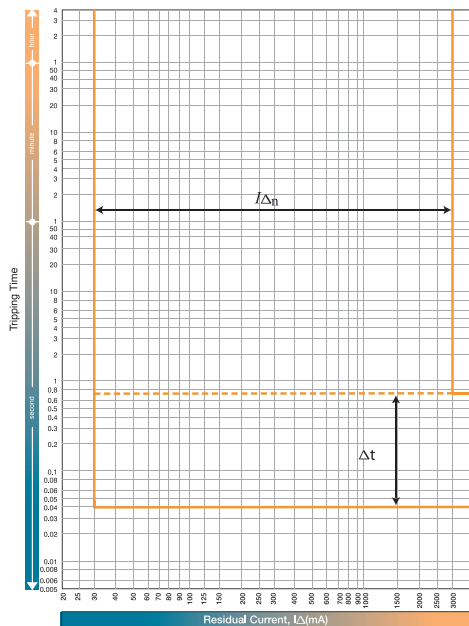

Internal accessories – series EB2

Ampere Frame size (A):

125

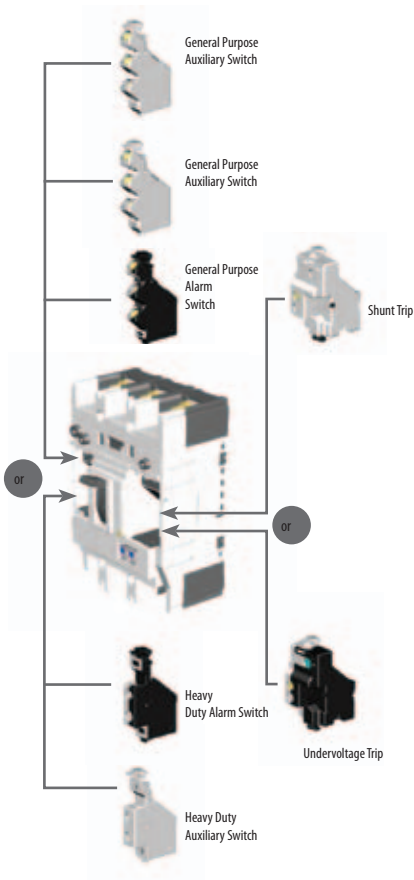

160 , 250

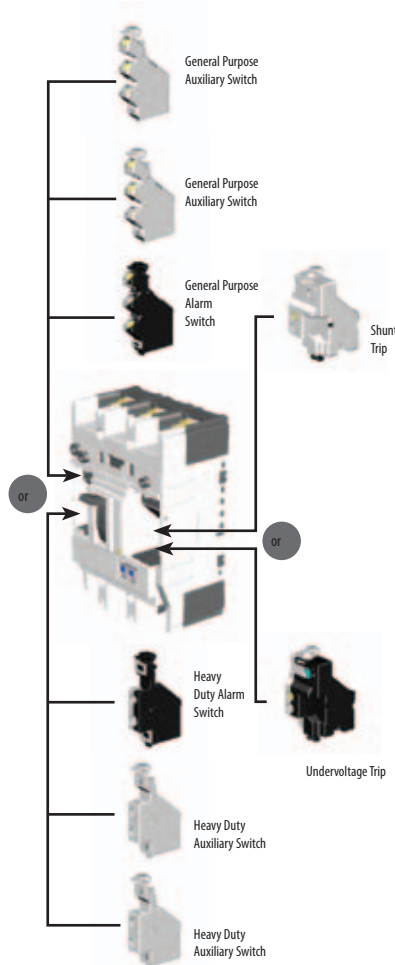

400 ... 1600

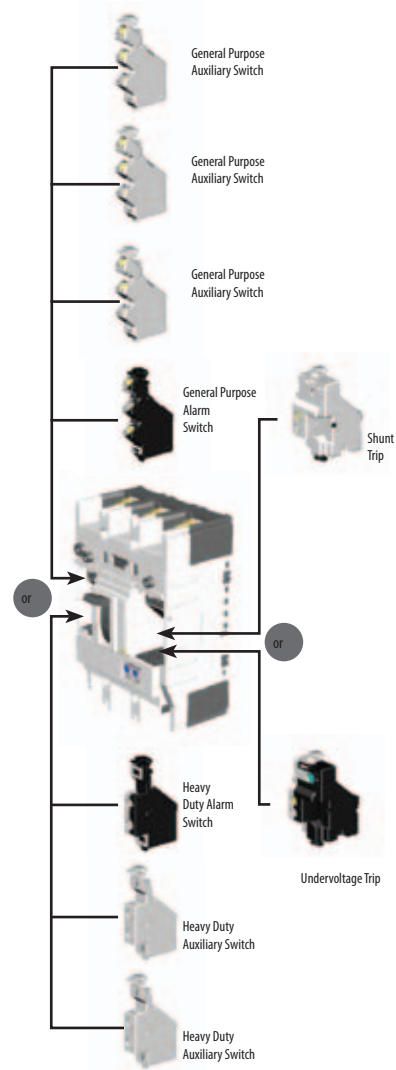

- Status indication switches mount in the left side of the MCCB. General purpose and heavy duty status indication switches cannot be mixed in the same MCCB. Only one alarm switch can be fitted to an MCCB.
- Shunt trips and undervoltage trips mount in the right side of the MCCB.
- It is not possible to install a shunt trip and an undervoltage trip in an MCCB as they occupy the same location. Undervoltage trips can provide remote tripping if necessary by wiring a normally closed contact or pushbutton in series with the protected supply.
- Undervoltage trips with time delays require an external time delay controller which clips to the side of the MCCB.

Internal accessories – series EB2



General Purpose Auxiliary Switch

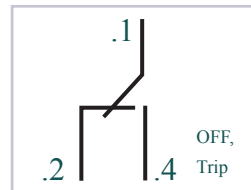

Terminal Designations and Function of General Purpose Auxiliary Switch



General Purpose Alarm Switch

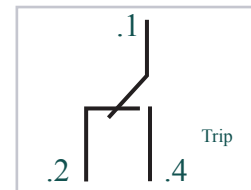

Terminal Designations and Function of General Purpose Alarm Switch

General purpose auxiliaries and alarm switch ratings

Volts (V)	AC Amperes (A)		Volts (V)	DC Amperes (A)		Minimum Load
	Resistive Load	Inductive Load		Resistive Load	Inductive Load	
440	-	-	250	-	-	100mA -> 15V DC.
240	3	2	125	0.4	0.05	
110	3	2	30	3	2	

Amperes (A)



Heavy Duty Auxiliary Switch

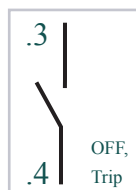

Terminal Designations and Function of Heavy Duty Auxiliary Switch NO contact



Heavy Duty Alarm Switch

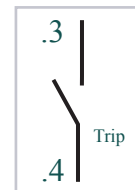

Terminal Designations and Function of Heavy Duty Alarm Switch, NO contact

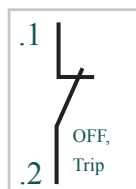

Terminal Designations and Function of Heavy Duty Auxiliary Switch, NC contact

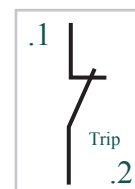

Terminal Designations and Function of Heavy Duty Alarm Switch, NC contact

Ratings of Heavy Duty Auxiliary and Alarm switches

Volts (V)	AC Amperes (A)		Volts (V)	DC Amperes (A)	
	Resistive Load	Inductive Load		Resistive Load	Inductive Load
440	3	3	250	0.5	0.5
240	4	4	125	1	1
110	5	5	48	3	2.5
48	6	6	24	6	2.5



Shunt Trips

Ratings of Shunt Trips						
Rated Voltage	Voltage AC		Voltage DC			
	200-240	380-450	24	48	100-120	200-240
Excitation Current (A)	0.014	0.0065	0.03	0.03	0.011	0.011

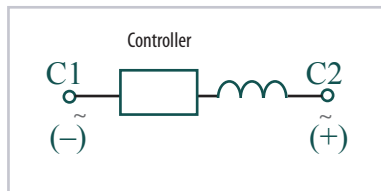

Terminal Designations of Shunt Trips



Undervoltage Trips

Ratings of Undervoltage Trips					
Rated Voltage	Power supply capacity (VA)		Excitation current (mA)		
	Voltage AC		Voltage DC		
	200-240	380-450	24	100-120	200-240
Power Supply Capacity (A)	1.4	2.28	23	10	10

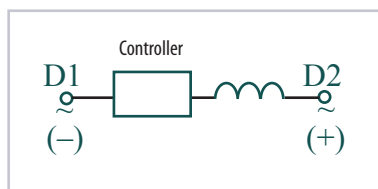

Terminal Designations of Undervoltage Trips

## External accessories

IZ – Interpole barrier. Installed between MCCB terminal, which increases the distance between poles to reduce the possibility of creepage.

PRS – Terminal cover. The terminal covers are applied to the MCCB to prevent accidental contact with live parts and thereby protection against direct contact.

PRS-ZB – Terminal cover for att. Busbar. The terminal covers are applied to the MCCB to prevent accidental contact with live parts and thereby protection against direct contact. The width is different because of attach busbar.

SP – Solderless terminal

RO – Operating handle, breaker mounted. It's used when MCCB is installed in control centre / switchboard

RO\_P – Operating handle, panel mounted, variable depth. This consists of an operating mechanism mounted on the breaker, an operating handle mounted on the panel door and a square shaft to connect the mechanism with the handle.

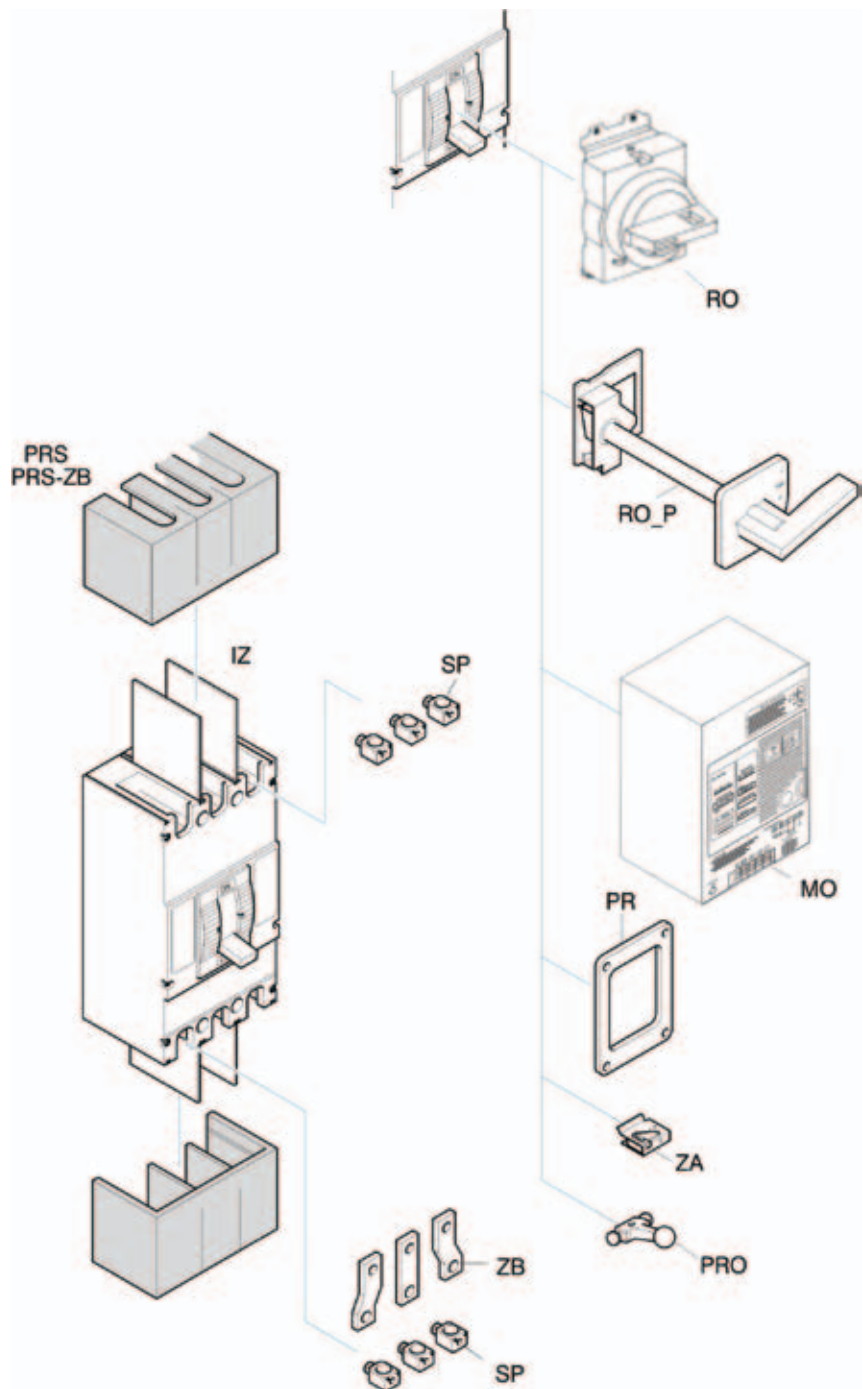

MO – Motor operator. Enabling to switch MCCB ON or OFF remotely.

PR – Door flange. Accessory for mounting on panel door.

ZA – Handle lock. Enables the MCCB to be padlocked in neither the ON or OFF position.

ZB – Attach busbar. Used for easier installation on busbar systems (widen terminals).

PRO – Handle extension. Used for easier manipulation ON/OFF at bigger MCCB's.

# Dimensions

## EB2 & EB2R 125

### Front connected

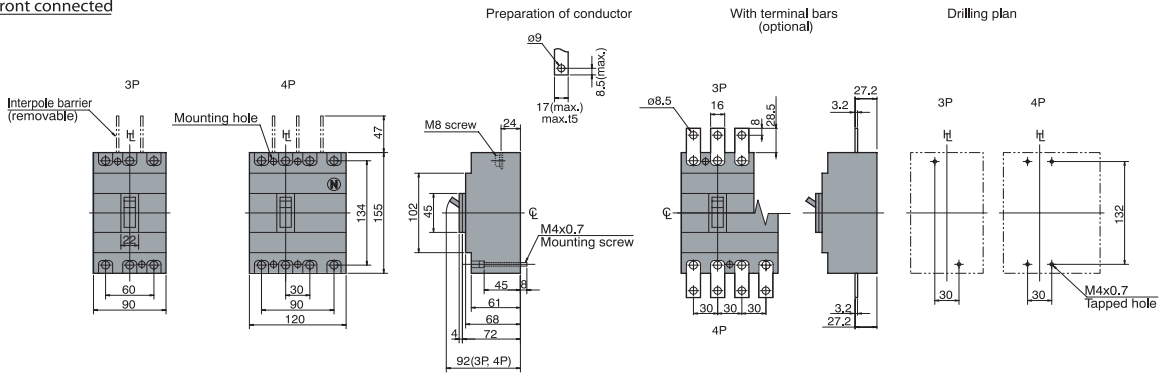

### Rear connected

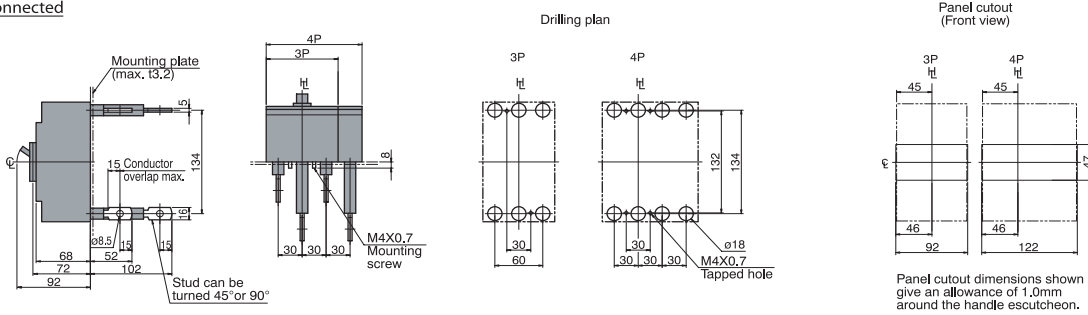

### Front connected with Motor Operator

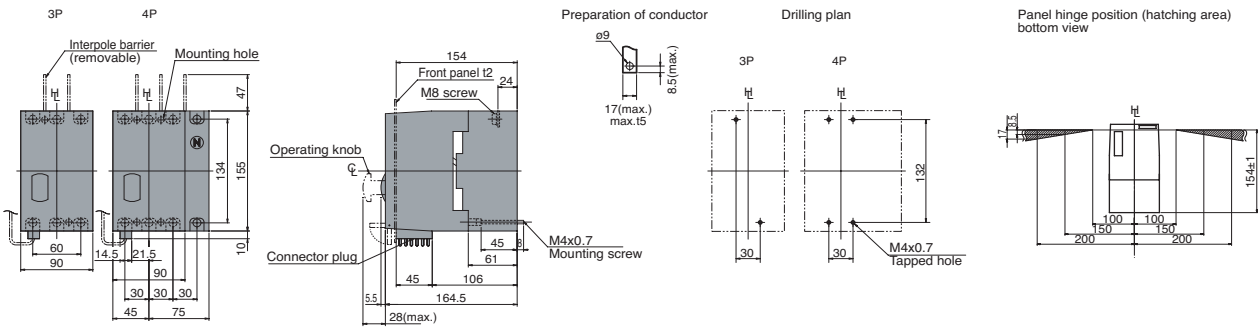

### Rear connected with Motor Operator

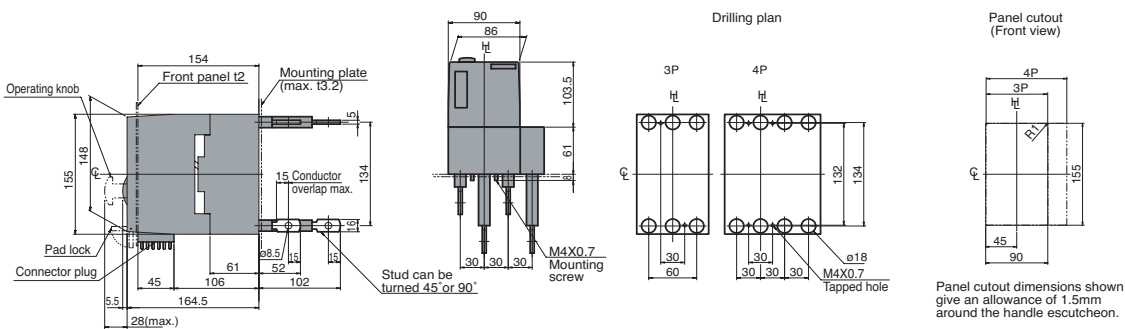



# Technical data

## EB2 160, EB2 250 & EB2R 250

### Front connected

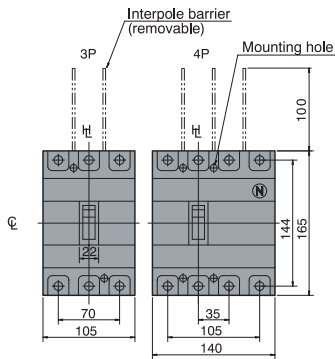

### Preparation of conductor

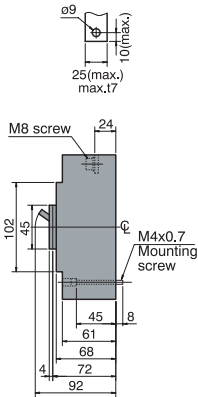

### With terminal bars (optional)

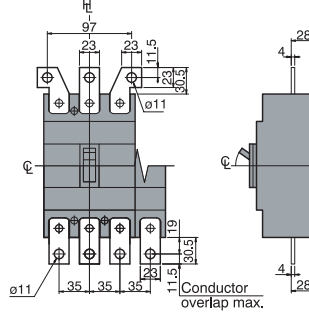

### Drilling plan

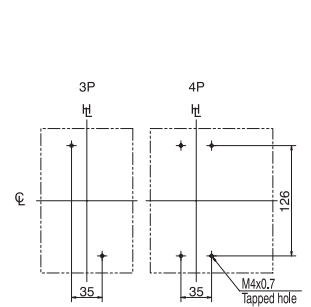

### Rear connected

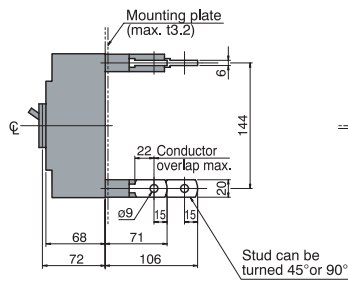

### Drilling plan

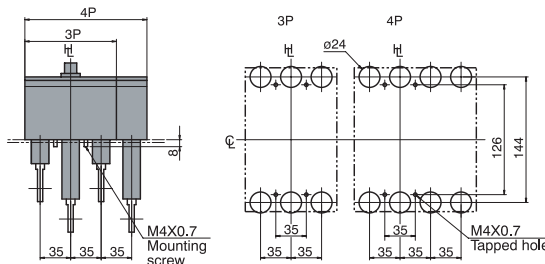

### Panel cutout (Front view)

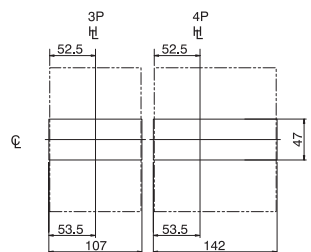

Panel cutout dimensions shown give an allowance of 1.0mm around the handle escutcheon.

### Front connected with Motor Operator

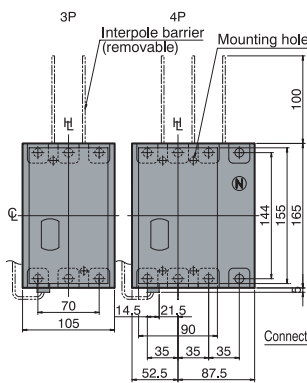

### Preparation of conductor

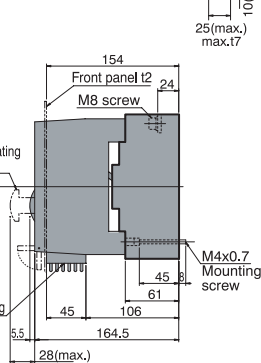

### Drilling plan

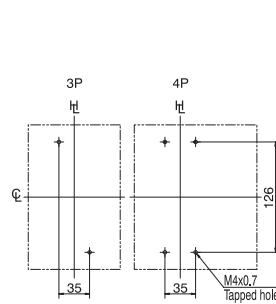

### Panel hinge position (hatching area) bottom view

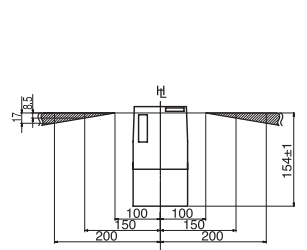

### Rear connected with Motor Operator

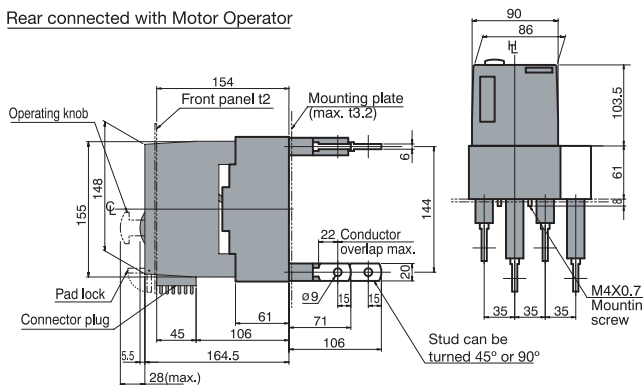

### Drilling plan

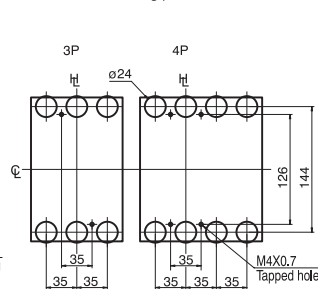

### Panel cutout (Front view)

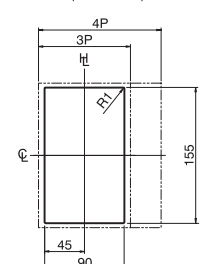

Panel cutout dimensions shown give an allowance of 1.5mm around the handle escutcheon.

# EB2 250/\_E (Microprocessor's MCCBs)

### Front connected

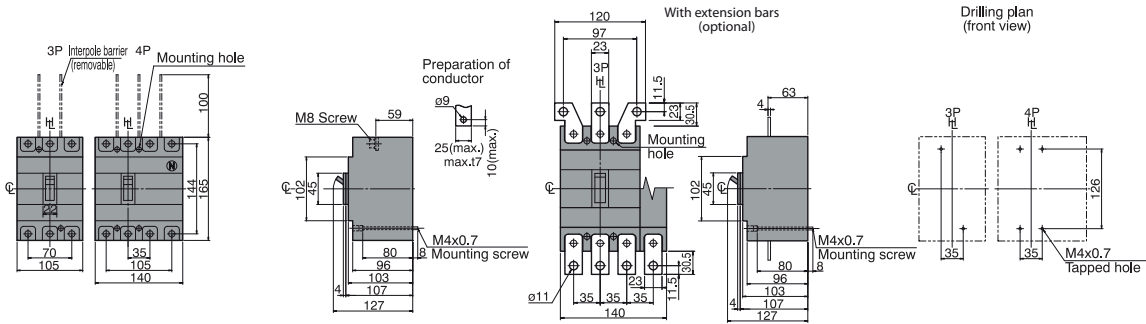

### Rear connected

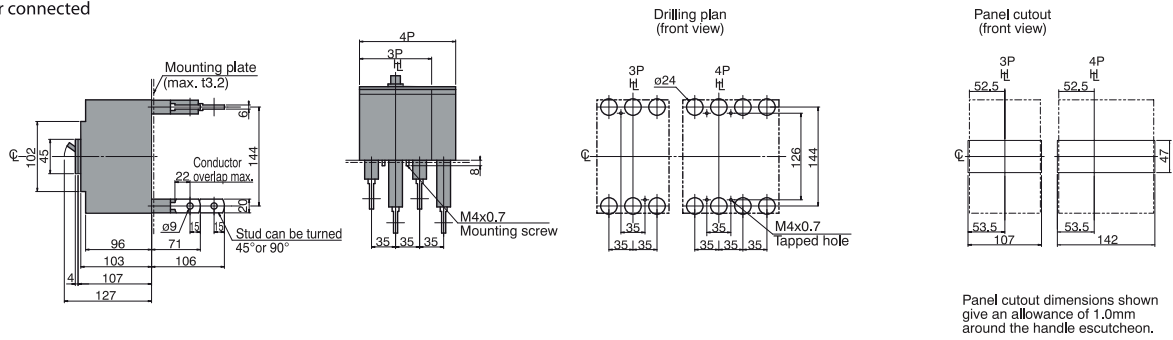

### Front connected with Motor Operator

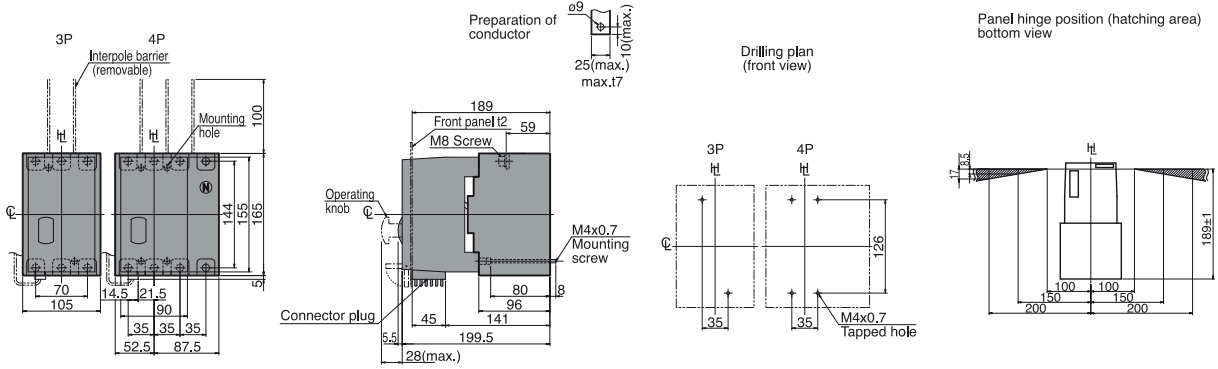

### Rear connected with Motor Operator

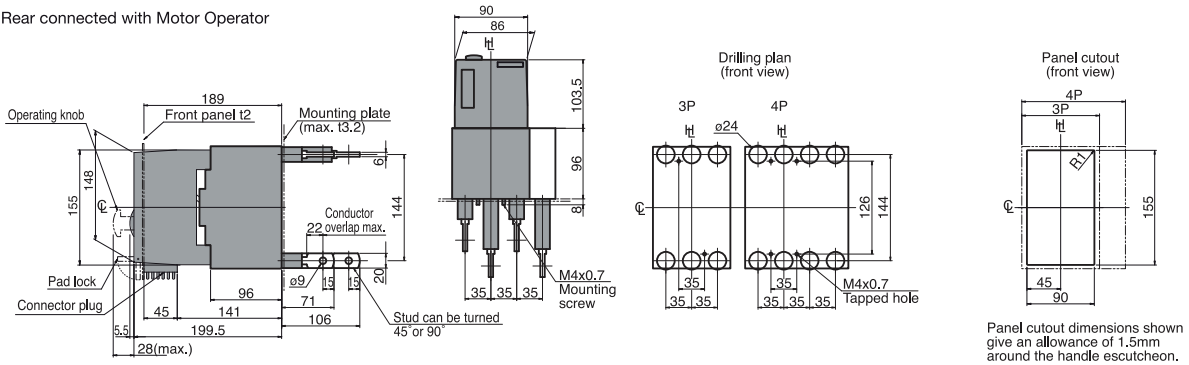

# Technical data

## EB2 400

### Front connected

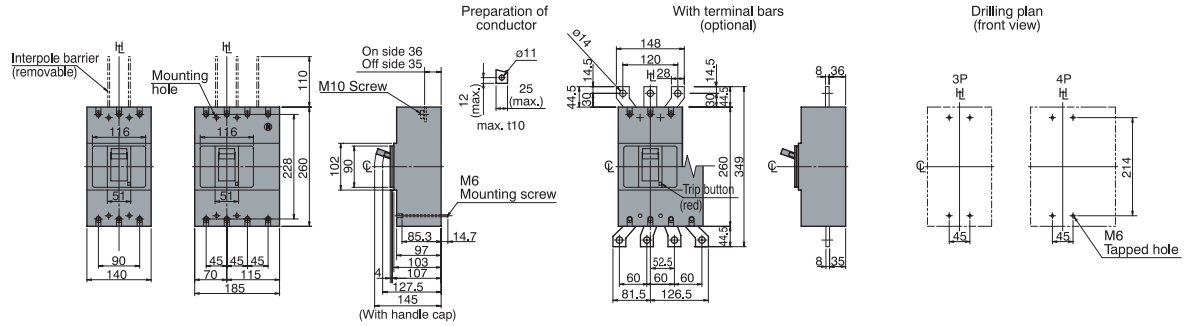

### Rear connected

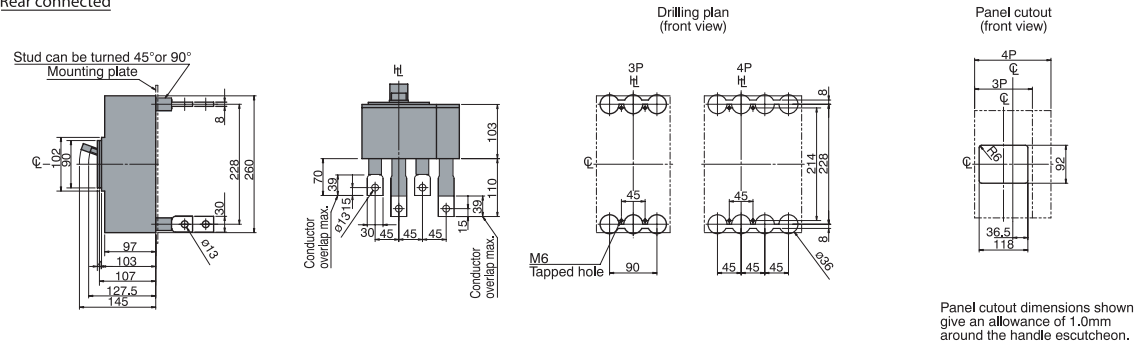

### Front connected with Motor Operator

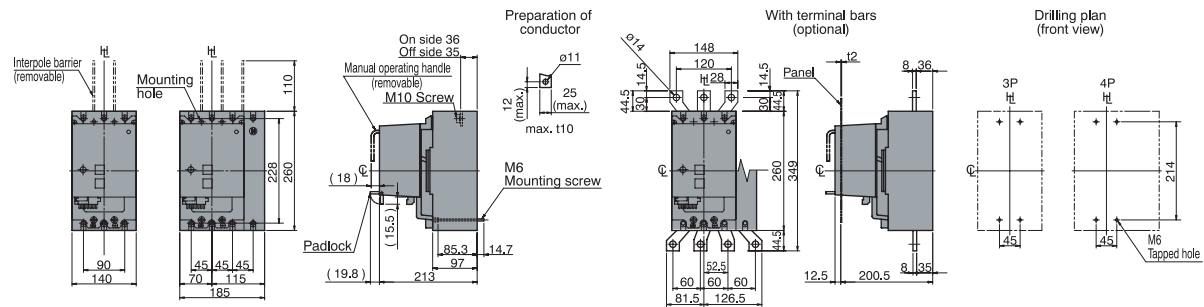

### Rear connected with Motor Operator

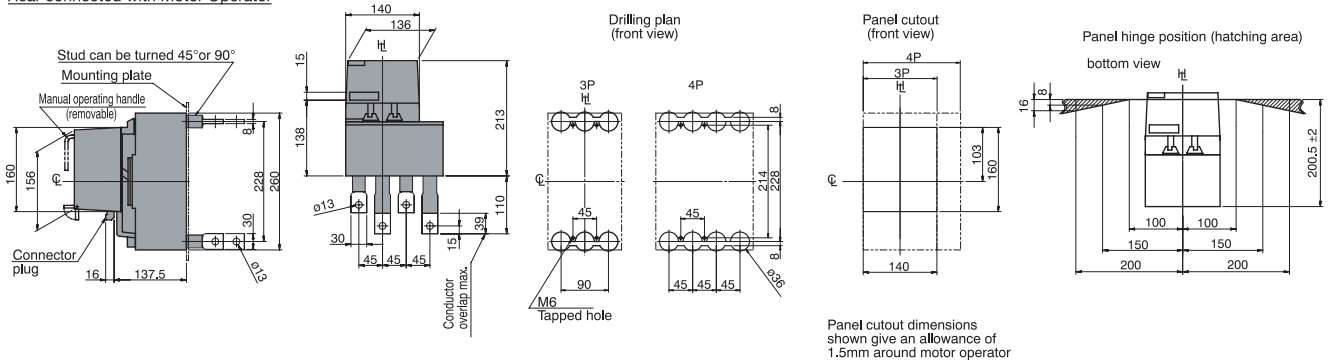

EB2 630

Front connected

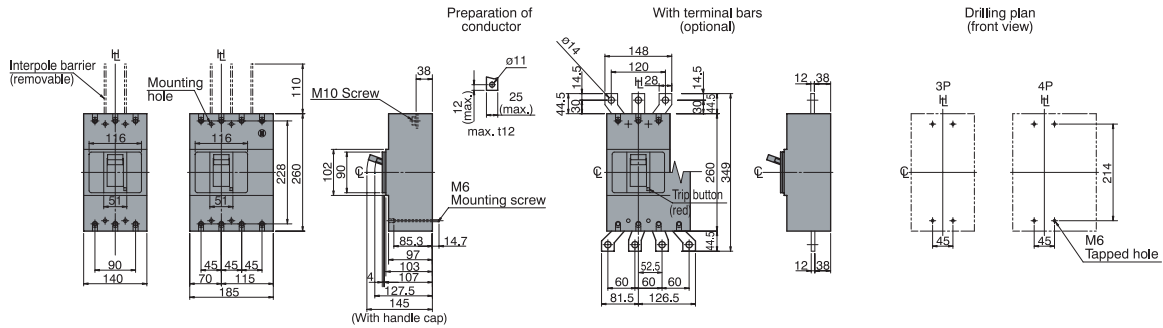

Rear connected

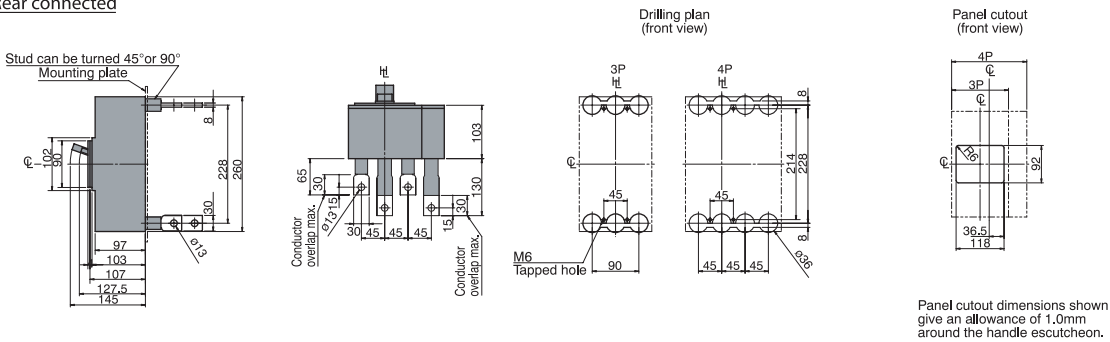

Panel cutout dimensions shown give an allowance of 1.0mm around the handle escutcheon.

Front connected with Motor Operator

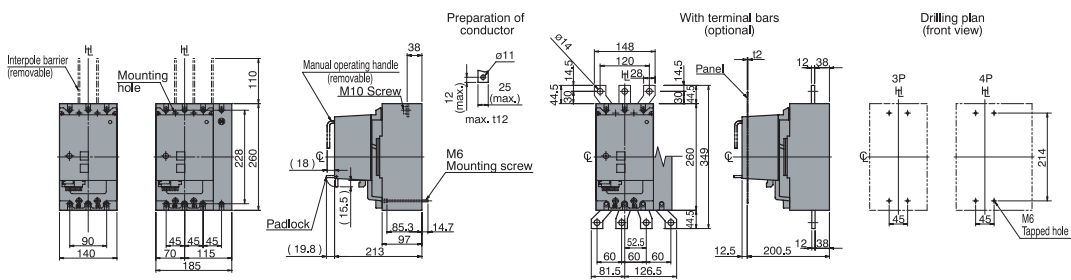

Rear connected with Motor Operator

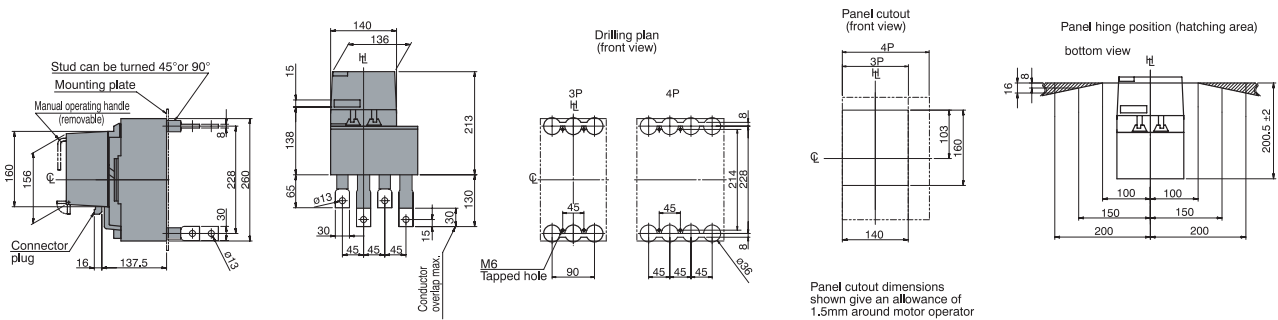

Panel cutout dimensions shown give an allowance of 1.5mm around motor operator

# Technical data

## EB2 800

### Front connected with extension bars (optional)

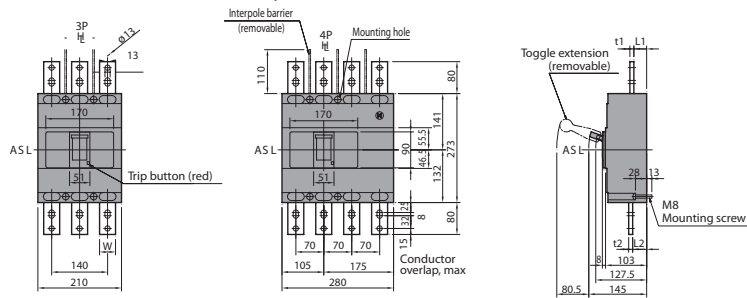

### Drilling plan (front view)

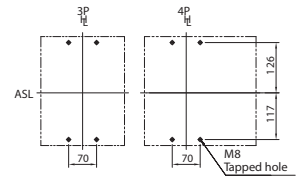

Breaker Type	Rated Current	t1	t2	L1	L2	W
EB2 800 Thermal magnetic	630A	8	8	32	34	40
	800A	10	10	32	35	40
EB2 800 Electronic	630A	8	8	32	36	40
	800A	10	10	32	36	40

### Rear connected

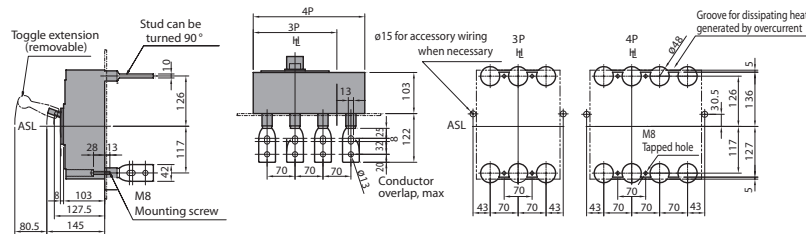

### Panel cutout (front view)

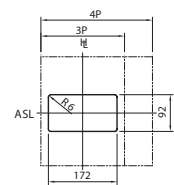

Panel cutout dimensions shown give an allowance of 1.0mm around the handle escutcheon.

Note: Studs are factory installed in horizontal direction both on the line and load sides.

### Front connected with Motor Operator

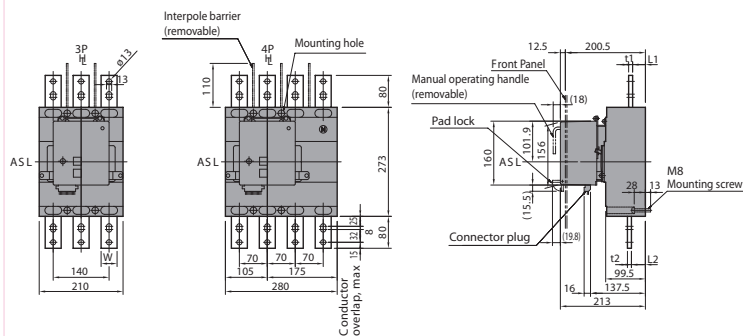

### Drilling plan (front view)

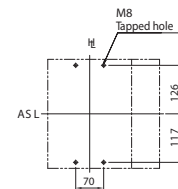

### Panel cutout (front view)

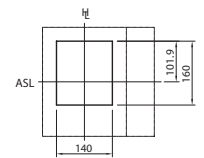

Panel cutout dimensions shown give an allowance of 1.5mm around motor operator.

### Rear connected with Motor Operator

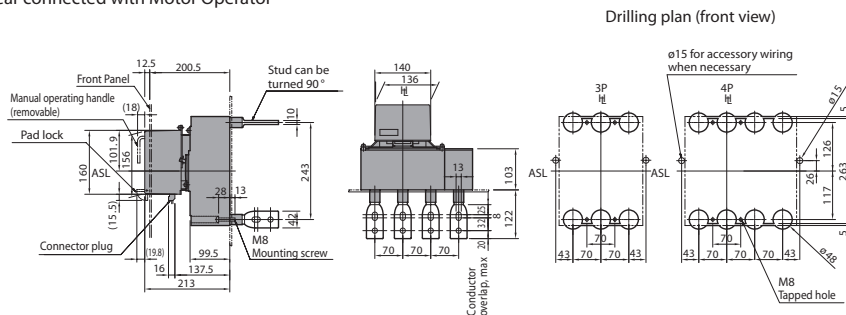

### Panel hinge position (hatching area) (bottom view)

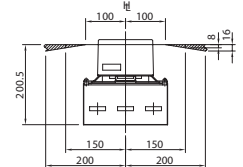

Note: Studs are factory installed in horizontal direction both on the line and load sides.

EB2 1000

Front connected

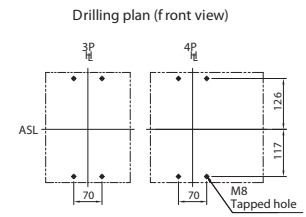
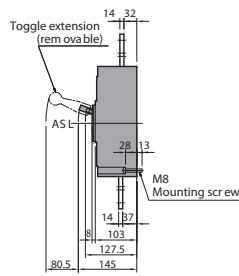
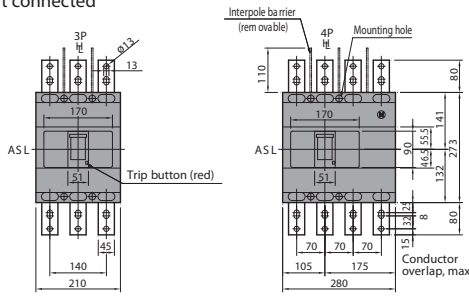

Rear connected

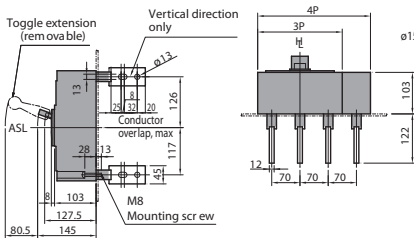

Drilling plan (front view)

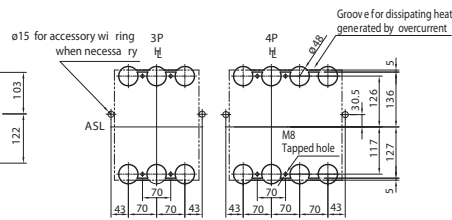

Panel cutout (front view)

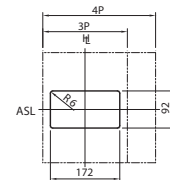

Panel cutout dimensions shown give an allowance of 1.0mm around the handle escutcheon.

Front connected with Motor Operator

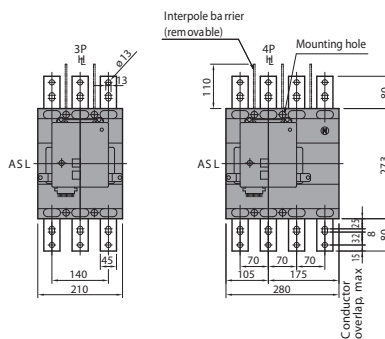

Drilling plan (front view)

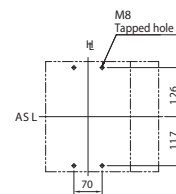

Panel cutout (front view)

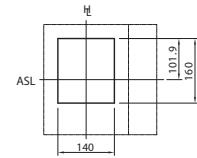

Panel cutout dimensions shown give an allowance of 1.5mm around motor operator.

Rear connected with Motor Operator

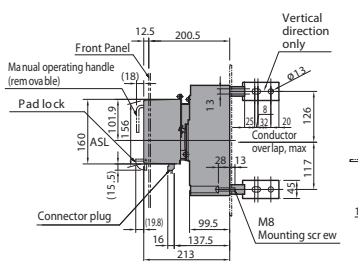

Drilling plan (front view)

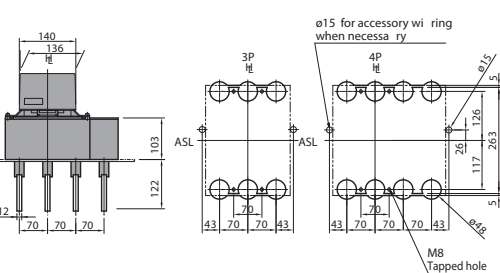

Panel hinge position (hatching area) (bottom view)

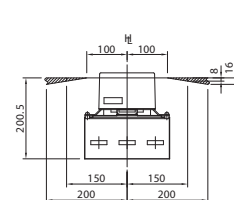

Note: Studs are factory installed in horizontal direction both on the line and load sides.

Technical data

EB2 1250

Front connected

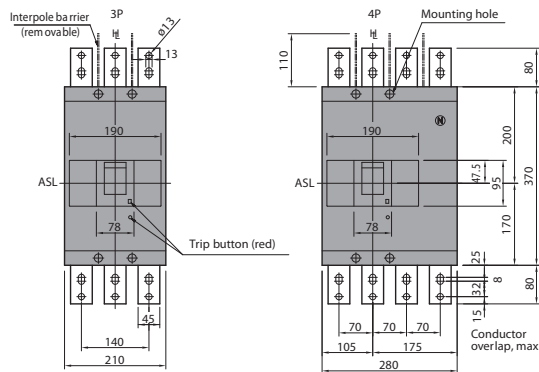

Drilling plan (front view)

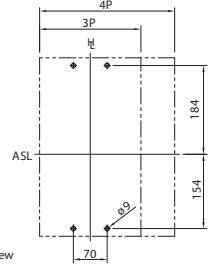

Rear connected

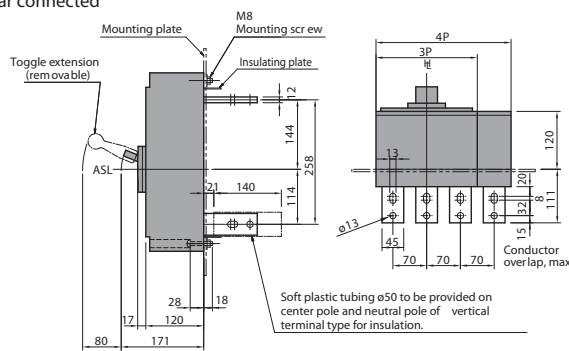

Drilling plan (front view)

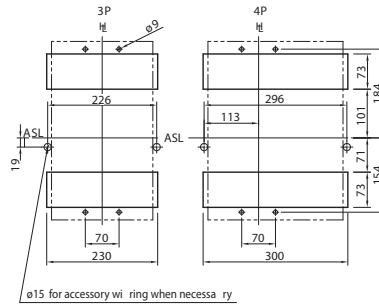

Panel cutout (front view)

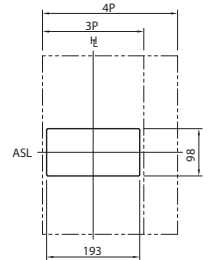

Panel cutout dimensions shown give an allowance of 1.5mm around the handle escutcheon.

Note: Studs are factory installed in horizontal direction both on the line and load sides.

Front connected with Motor Operator

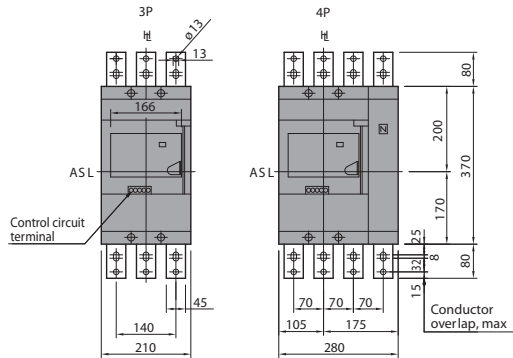

Drilling plan (front view)

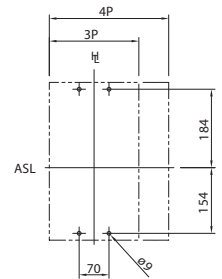

Rear connected with Motor Operator

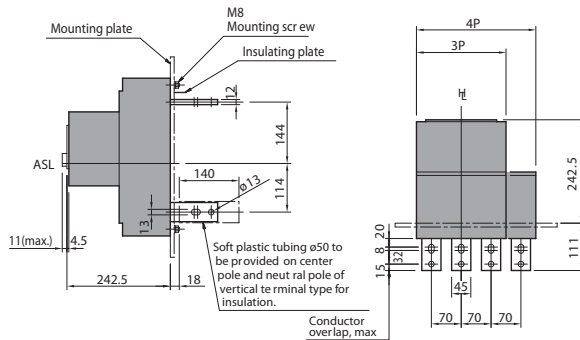

Drilling plan (front view)

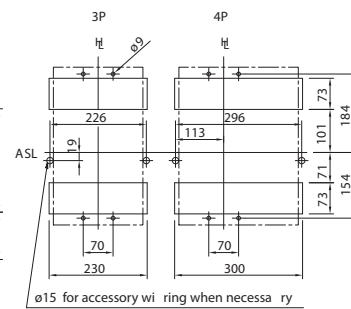

Panel cutout (front view)

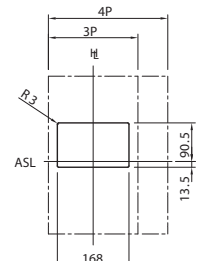

Panel cutout dimensions shown give an allowance of 1.0mm around motor operator.

Note: Studs are factory installed in horizontal direction both on the line and load sides.

EB2 1600

Front connected

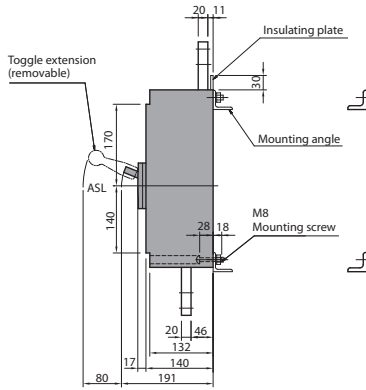
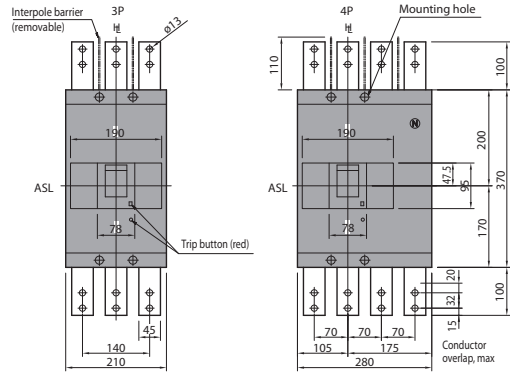

Drilling plan (front view)

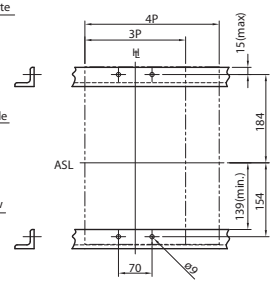

Rear connected

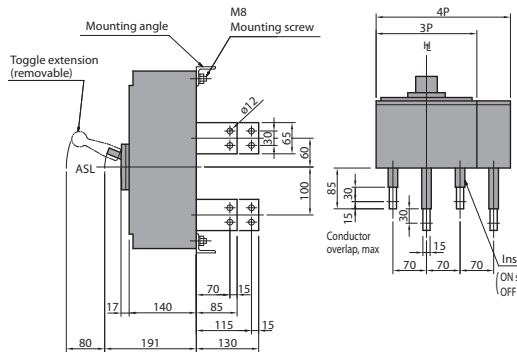

Drilling plan (front view)

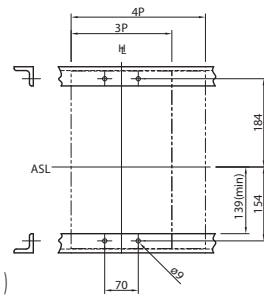

Panel cutout (front view)

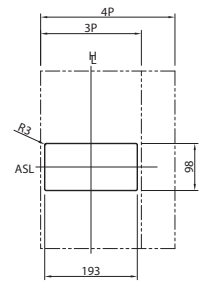

Panel cutout dimensions shown give an allowance of 1.5mm around the handle escutcheon.

Front connected with Motor Operator

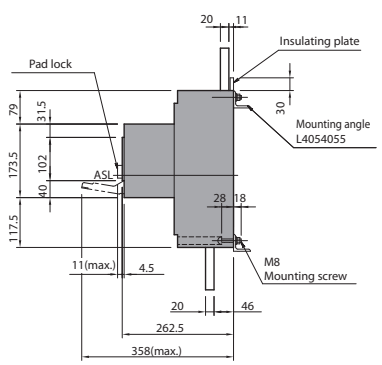
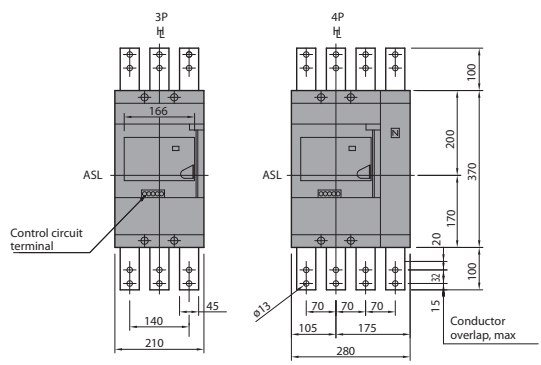

Drilling plan (front view)

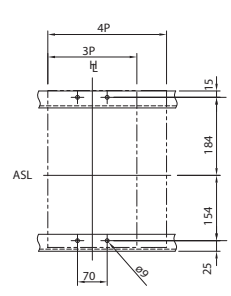

Rear connected with Motor Operator

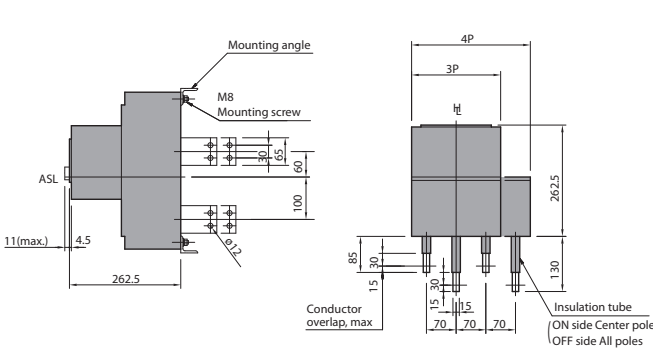

Drilling plan (front view)

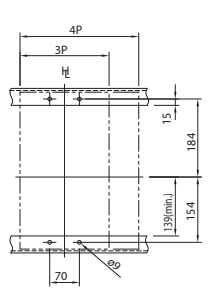

Panel cutout (front view)

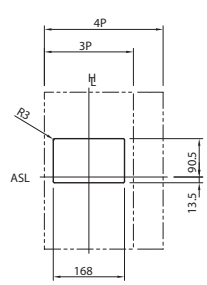

Panel cutout dimensions shown give an allowance of 1.0mm around motor operator.