



## INSTALLATION INSTRUCTIONS FOR PART 99-82295

### APPLICATIONS

# Toyota Sienna 2011-2014 99-82295

### KIT FEATURES

- ISO DIN radio provision with pocket
- Double DIN radio provision
- *Painted silver to match factory dash*



### KIT COMPONENTS

- A) Radio housing • B) Radio housing brackets • C) Pocket • D) (8) #8 x 3/8" Phillips screws

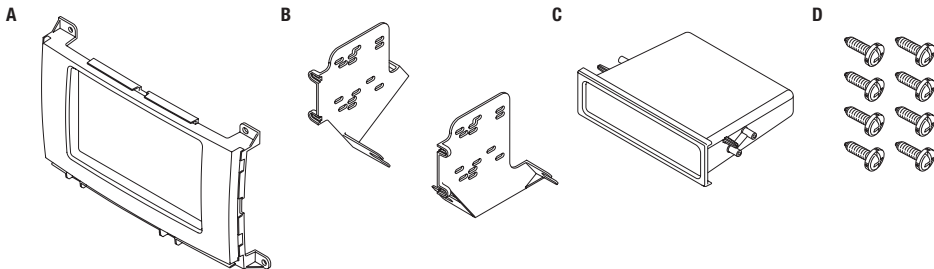

### WIRING & ANTENNA CONNECTIONS (sold separately)

#### Wiring Harness:

- 70-1761 - Toyota harness 1987-up
- TYTO-01 - Toyota premium sound interface 2006 -up

#### Antenna Adapter:

- Not required

### TOOLS REQUIRED

- Phillips screwdriver • Panel removal tool/flat blade screwdriver • Socket wrench

**CAUTION:** Metra recommends disconnecting the negative battery terminal before beginning any installation. All accessories, switches, and especially air bag indicator lights must be plugged in before reconnecting the battery or cycling the ignition.

**NOTE:** Refer to the instructions included with the aftermarket radio.

## Table of Contents

### Dash Disassembly

– Toyota Sienna 2011-2014.....2

### Kit Assembly

– ISO DIN radio provision with pocket.....3

– Double DIN radio provision .....3

1. Unclip and remove the trim panel above the glove box and below the A/C control. (Figure A)
2. Unclip and remove the shifter trim panel. (Figure B)

*Continued on next page*

## Toyota Sienna 2011-2014

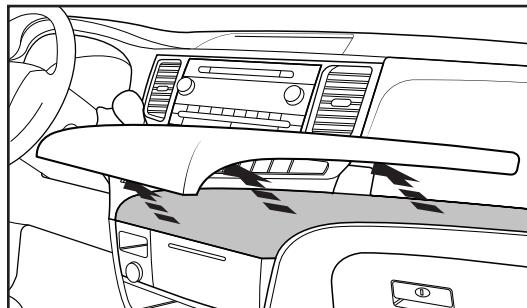

(Figure A)

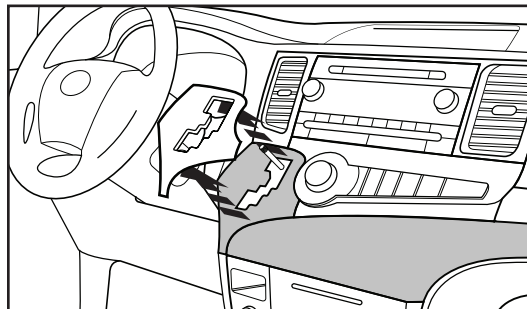

(Figure B)

**Toyota Sienna 2011-2014**

3. Unclip and remove the A/C control. (Figure C)
4. Remove (4) 10 mm bolts securing the radio. (Figure D)
5. Remove the (4) Phillips screws securing the outer A/C vent trim panel to the factory radio and separate. (Figure E)

*Continued on kit assembly*

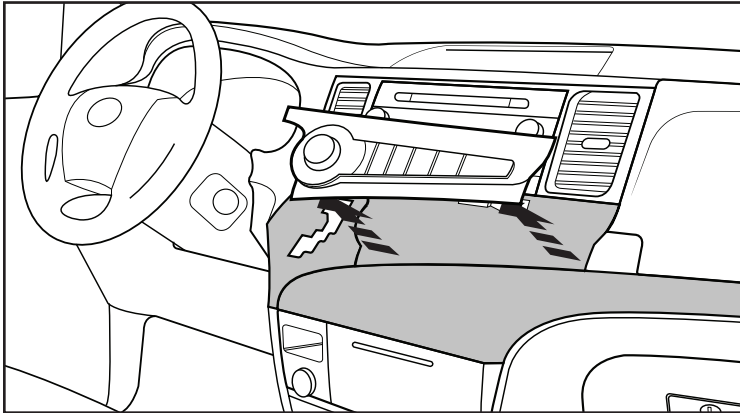

(Figure C)

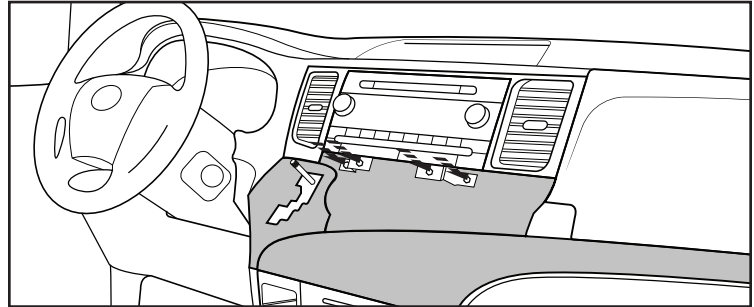

(Figure D)

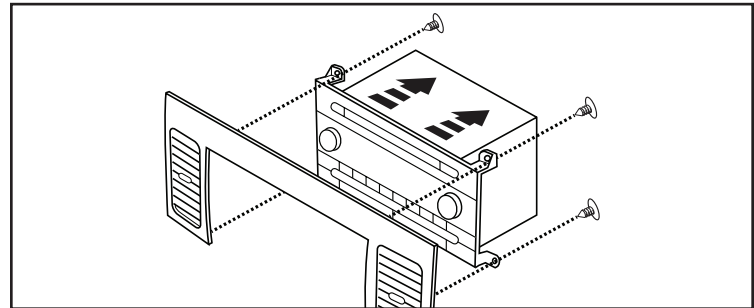

(Figure E)



## Kit Assembly 99-82295

### ISO DIN radio provision with pocket

1. Secure the radio housing brackets to the radio housing with four #8 3/8" Phillips screws provided. (Figure A)
2. Attach the pocket to the bracket/radio housing assembly with the four #8 3/8" Phillips screws provided. (Figure B)
3. Align the holes in the radio housing brackets with the holes in the ISO DIN radio and secure the brackets to the radio with the screws included with the radio. (Figure C)
4. Attach the outer a/c vent trim panel to the radio housing using the factory hardware. (Figure D)
5. Locate the factory wiring harness in the dash. Metra recommends using the proper mating adapter from Metra or AXCESS. Re-connect the negative battery terminal and test the radio for proper operation.
6. Reassemble dash in reverse order of disassembly.

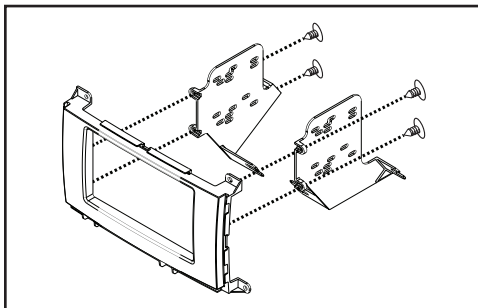

(Figure A)

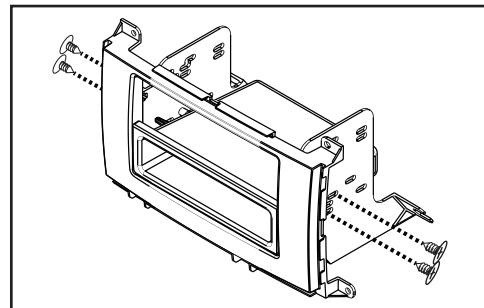

(Figure B)

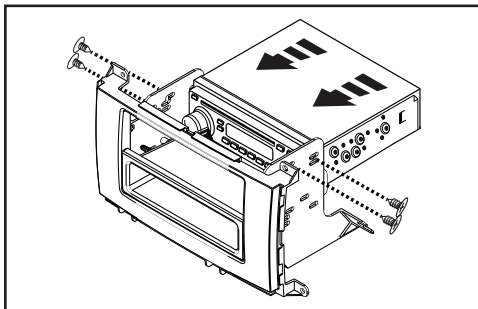

(Figure C)

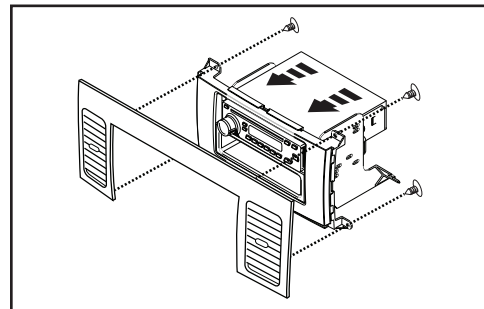

(Figure D)



## Kit Assembly 99-82295

### Double DIN radio provision

1. Secure the radio housing brackets to the radio housing with four #8 x 3/8" Phillips screws provided. (Figure A)
2. Slide the double DIN radio into the bracket/radio housing assembly and secure to the assembly using the screws supplied with the radio. (Figure B)

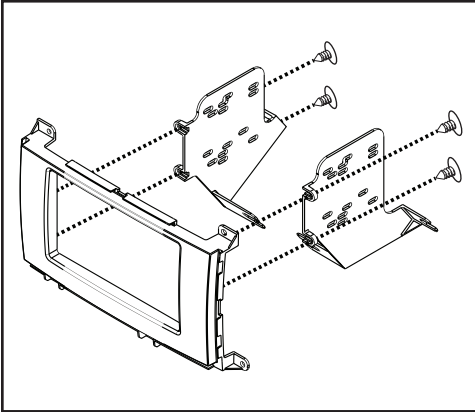

(Figure A)

3. Attach the outer A/C vent trim panel to the radio housing using the factory hardware. (Figure C)
4. Locate the factory wiring harness in the dash. Metra recommends using the proper mating adapter from Metra or AXCESS. Re-connect the

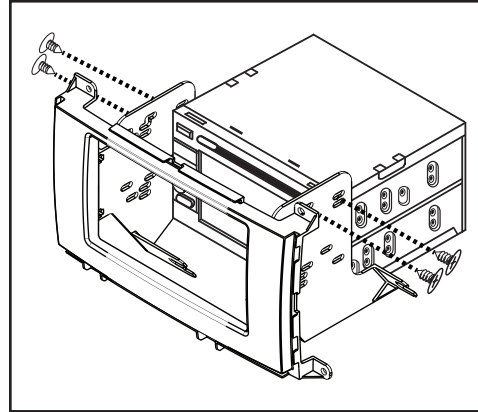

(Figure B)

negative battery terminal and test the radio for proper operation.

5. Reassemble dash in reverse order of disassembly.

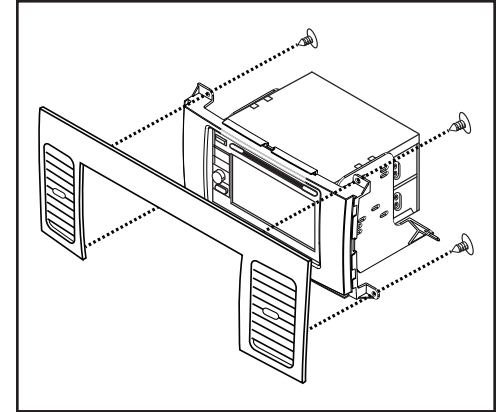

(Figure C)



99-82295

## Notes

---

---

---

---

---

---

---

---

---

---

---

---

---

---

---

---

---

---

---

---

---

---

---





## INSTALLATION INSTRUCTIONS FOR PART 99-82295



REV. 9/24/2014 INST99-82295



### KNOWLEDGE IS POWER

Enhance your installation and fabrication skills by enrolling in the most recognized and respected mobile electronics school in our industry. Log onto [www.installerinstitute.com](http://www.installerinstitute.com) or call 800-354-6782 for more information and take steps toward a better tomorrow.



**Metra recommends MECP certified technicians**