

PC Board Layout

Tolerance: +/-0.05mm

DESCRIPTION

- ◆ 10/100 BASE-TX RJ45 1X1 TAB-DOWN WITH LEDS INTEGRATED MAGNETICS CONNECTOR (ICM).

FEATURES AND BENEFITS

- ◆ ROHS PEAK WAVE SOLDER TEMPERATURE RATING 260° C.
- ◆ RJ45 1X1 8-PIN WITH INTERNAL MAGNETIC;
- ◆ SUITABLE FOR CAT5 AND CAT6 FAST ETHERNET CABLE OR BETTER UTP.
- ◆ INTERNAL MANETICS: 100% ELECTRONICALLY TESTED FOR HI POT AND FUNCTIONALITY.

ELECTRICAL PERFORMANCE SUMMARY

- ◆ MEETS IEEE802.3 SPECIFICATION AND 350uH MINIMUM OCL WITH 8mA BIAS CURRENT.
- ◆ HIGH PERFORMANCE FOR MAXIMUM EMI SUPPRESSION.

TEMPERATURE PERFORMANCE

- ◆ STORAGE TEMPERATURE RANGE: -25° C TO +85° C.
- ◆ OPERATION TEMPERATURE RANGE: 0° C TO +70° C.

MATERIAL SPECIFICATION

- ◆ SHIELD: BRASS, 0.2mm THICKNESS WITH NICKEL PLATED.
- ◆ HOUSING: PA6T UL94V-0.
- ◆ CONTACT: PHOSPHOR BRONZE, 0.35mm THICKNESS, SELECTIVE GOLD PLATING.

Ordering Information

LMJ302881X5CNL

Contact Plating

- 1 = 15u" gold
- 2 = 30u" gold
- 3 = 50u" gold
- 4 = 6u" gold
- 5 = G/F



TOLERANCE (mm)	APPROVALS	DATE	TITLE	AMPHENOL Amphenol European Design Center	
X, ±0.3	DRAWN Stephane	2014/May/8	RJ45 100BASE-TX R/A DIP TAB Down w/LED	Scale N.A.	Sheet 1 of 2
X.X ±0.20	CHECKED Rob	2014/May/8			
X.XX ±0.15	APPROVED Rob	2014/May/8			
UNLESS OTHERWISE SPECIFIED	UNIT: mm		SIZE: A4	DRAWING N°: LMJ302881X5CNL	REV. B

ELECTRONICAL

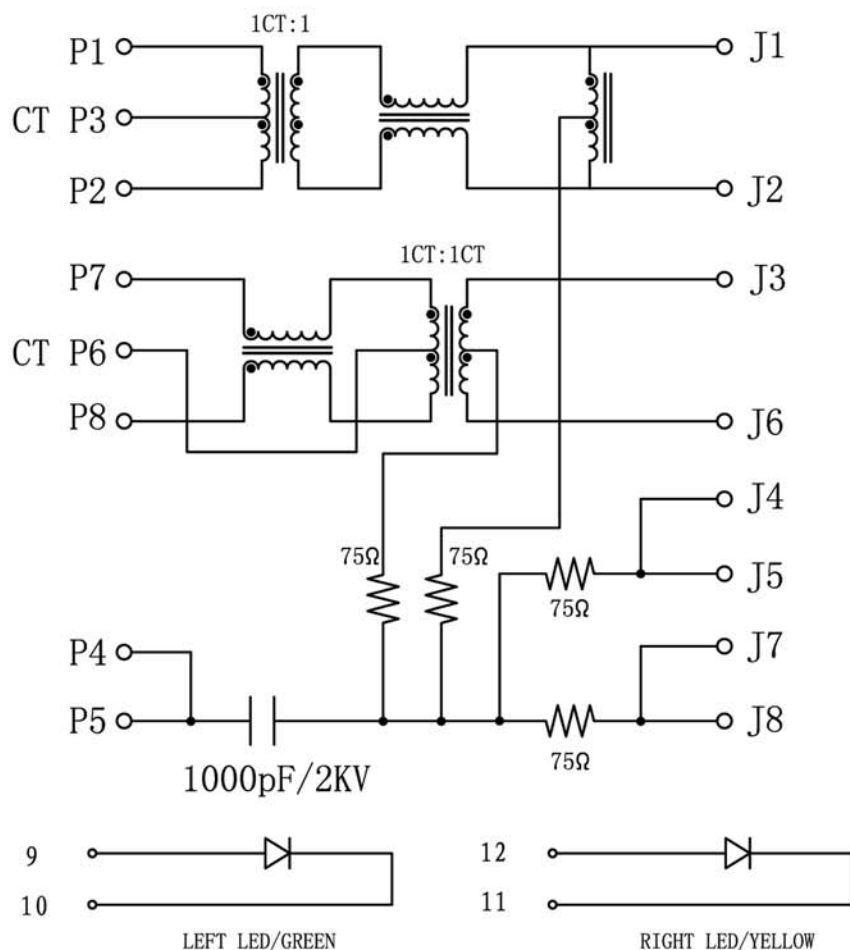

ELECTRICAL SPECIFICATIONS

- ◆ ALL TEST CONDITIONS @ 25°C UNLESS OTHERWISE NOTED.
- ◆ TURN RATIO:
 - TX, SECONDARY : PRIMARY = 1CT:1CT ± 3%.
 - RX, SECONDARY : PRIMARY = 1CT:1CT ± 3%.
- ◆ OCL: 350uH MIN, 8mA DC BIAS CURRENT.
- ◆ INSERTION LOSS: 1-100MHZ - 1.0dB MAX.
- ◆ RETURN LOSS:

1MHZ TO 10MHZ	: -18dB MIN.
10MHZ TO 30MHZ	: -16dB MIN.
30MHZ TO 60MHZ	: -14dB MIN.
60MHZ TO 80MHZ	: -12dB MIN.
80MHZ TO 100MHZ	: -10dB MIN.
- ◆ CROSSTALK: 1MHZ TO 100MHZ : -35dB MIN.
- ◆ COMMON MODE REJECTION: 1-100MHZ : -35dB MIN.
- ◆ HIPOT: 1500V AC 1mA 1S.
- ◆ CAPACITOR: 1000pF ± 25% 2KV.
- ◆ RESISTANCE: 75OHMS ± 20%.
- ◆ RESISTANCE OF COIL: 1.8OHMS MAX, 0.25OHMS MIN.
- ◆ LEFT LED COLOR: GREEN; RIGHT LED COLOR: YELLOW.



TOLERANCE (mm)	APPROVALS	DATE	TITLE	AMPHENOL Amphenol European Design Center	
X, ±0.3	DRAWN Stephane	2014/May/8	RJ45 100BASE-TX R/A DIP TAB Down w/LED	Scale N.A.	Sheet 2 of 2
X.X ±0.20	CHECKED Rob	2014/May/8			
X.XX ±0.15	APPROVED Rob	2014/May/8			
UNLESS OTHERWISE SPECIFIED	UNIT : mm		SIZE : DRAWING N° A4	LMJ302881X5CNL	REV. B