

1 2 3 4 5 6

length when assembled app. 55.5

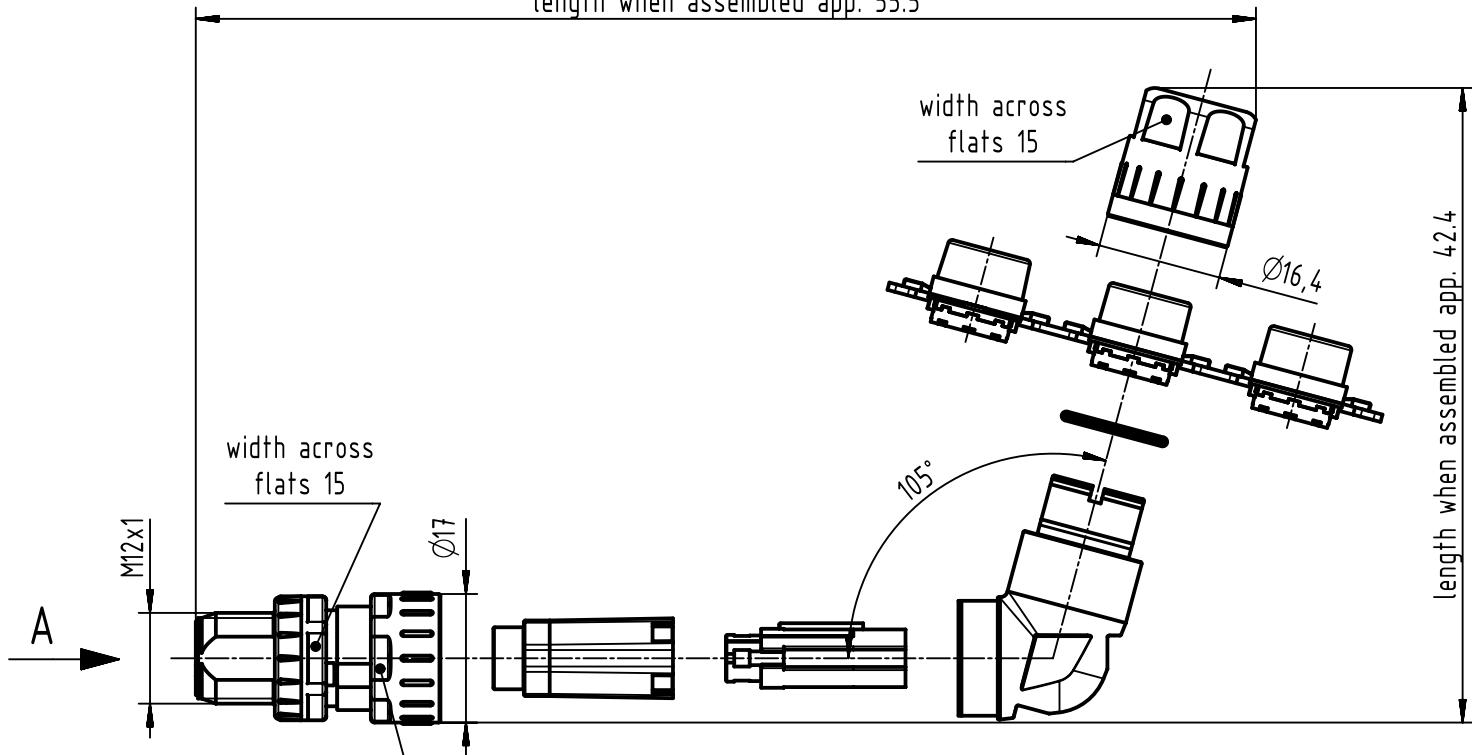

A (2:1)
contact face acc. to
IEC 61076-2-101

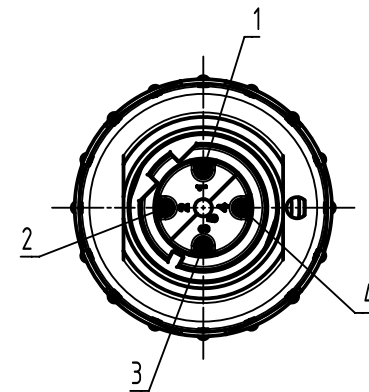

width across flats 15

width across flats 15

length when assembled app. 42.4

M12x1

Ø17

order contacts separately

width across flats 16



assembly aid enclosed

cable Ø	wire gauge	part-no.
5.7-8.8mm	AWG 26-22	09 67 000 5576
	AWG 24-20	09 67 000 8576
	AWG 22-18	09 67 000 3576

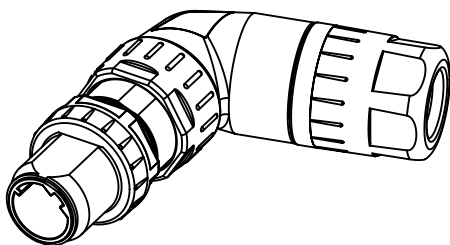

	All rights reserved Department EC PD - DE	All Dimensions in mm Original Size DIN A4			Scale 1:1	Free size tol.		Ref. Sub.		
		HARTING Electronics GmbH D-32339 Espelkamp	Created by BUSSMANT	Inspected by GENAU	Standardisation HOFFMANN	Date 2015-11-16	State Final Release		Doc-Key / ECM-Nr. 100591011/UGD/002/B 500000097193	
		Title HARTING M12 Slim Design angled male D-coded 4-pole						Rev. B		Page 1/1
		Type TB		Number 21038813405						